

John Dee
Mysteriorum

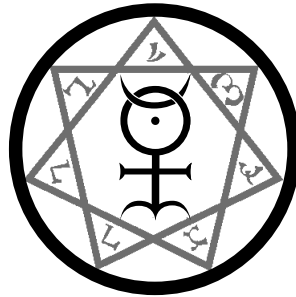

The materials in this book are copyright © 1998 Clay Holden and the
the John Dee Publication Project. All rights reserved.

Booksign & joining of books 1,2 & 3 by Caput Mortuum for the Ayin Quadma'ah Movement.

Elias Ashmole's Preface:

Be it remembred, That the 20th: of August 1672, I received by the hands of my Servant Samuell Story, a parcell of Dr: Dee's Manuscripts, all written with his owne hand; vizt: his Conferences with Angells, which first began the 22th of Dec: anno: 1581, & continued to the end of May anno: 1583, where the printed Booke of the remaining Conferences (published by Dr: Casaubon) begins, & are bound up in this volume.

Beside these, the Booke intituled, *The 48 Claves Angelicæ*, also, *Liber Scientia Terrestris Auxilii & Victoria* (These two being those very individuall Bookes which the Angells commanded to be ⁺burnt , & were after ⁺⁺restored by them as appeares by the printed Relation of Dr: Dee's Actions with Spirits pag: 418 & 419) The Booke intituled *De Heptarchia Mystica Collectaneorum Lib: Primus*, and a Booke of *Invocations or Calls*, begining with the Squares filld with letters, about the Black Cross.

These 4 Bookes I have bound up in another volume.

All which, were a few daies before delivered to my said Servant, for my perusall (I being then at Dr: William Lillies house at Hersham in Surrey) by my good freind Mr: Thomas Wale, one of his Majesties Warders in the Tower of London.

+10. April } 1586
+30. April }



The 5th: of Sept: following Mr: Wale (having heard of my retourne to Towne) came to my office in the Excise Office in Broadstreete, & told me he was content to exchange all the foresaid Bookes, for one of myne, *vizt:* *The Institution, Lawes & Ceremonies of the most Noble Order of the Garter*, to this I agreed, and provided one, which I sent him fairely bound, & gilt on the Back.

As a further testimony of the sence of Mr. Wales kindnes; shortly after his death, I sent for his son, & bestowed on him, one of my Deputyes places in the Excise, with an allowance of 80 £ per Annum.

On the 10th: of the said Sept: Mr: Wale came thither to me againe, & brought his wife with him, from her I received the following account of the preservation of these Bookes, even till they came to my hands, *vizt:* That her former Husband was one Mr: Jones a Confectioner, who formerly dwelt at the Plow in Lumbardestreet London, & who, shortly after they were married, tooke her with him into Alde streete among the Joyners, to buy some Houshold stuff, where (at the Corner house) they saw a Chest of Cedarwood, about a yard & halfe long, whose Lock & Hinges, being of extraordinary neate worke, invited them to buy it. The Master of the shop told them it had ben parcell of the Goods of Mr: John Woodall Chirurgeon (father to Mr: Tho: Woodall Late Serjant Chirurgeon to his now Majestie King Charles the 2d: (my intimate friend) and tis very probable he bought it after Dr: Dee's death, when his goods were exposed to Sale.

Twenty yeares after this (& about 4 yeares before the fatall Fire of London) she & her said husband occasionally removing this Chest out of its usuall place, thought they heard some loose thing rattle in it, toward the right hand end, under the Box or Till thereof, & by shaking it, were fully satisfied it was so: Hereupon her Husband thrust a peece of Iron into a small Crevice at the bottome of the Chest, & thereupon appeared a private drawer, which being drawne out, therein were found divers Bookes in Manuscript, & papers, together with a litle Box, & therein a Chaplet of Olive Beades, & a Cross of the same wood, hanging at the end of them.

They made no great matter of these Bookes &c: because they understood them not, which occasioned their servant Maide to wast about one halfe of them under Pyes & other like uses, which when discovered, they kept the rest more safe.

About two yeares after the discovery of these Bookes, Mr: Jones died, & when the fire of London hapned, though the Chest perished in the Flames, because not easily to be removed, yet the Bookes were taken out & carried with the rest of Mrs: Jones her goods into Moorefields, & being brought safely back, she tooke care to preserve them; and after marrying with the foresaid Mr: Wale, he came to the knowledge of them, & thereupon, with her consent, sent them to me, as I have before set downe.

Anno 1581 : 1582

Mysteriorum

Liber Primus

Mortlací

+ 1 +

*Præter alias meas extemporaneas preces, et ejaculationes
ad Deum vehementiores: Hæc una, maxime
usitata fuit*

*Oratio mea Matutina, Vespertinaque: pro Sapientia.
In nomine Dei Patris, Dei Filii, Dei Spiritus Sancti
Amen.*

*Omnipotens, Sempiterna, vere, et vive Deus, in adjutorium meum
intende: Domine Dominantium, Rex Regum, Jeovah
Zebaoth, ad adjuvandum me festina:*

*Gloria Deo, Patri, Filio, et spiritui Sancto: Sicut erat in
principio, et nunc, et semper et in sæcula sæculorum: Amen.*

*Recte sapere, et intelligere doceto me, (ô rerum omnium Creator,) Nam
Sapientia tua, totum est, quod volo: Da verbum tuum in ore meo,
(ô rerum omnium Creator,) et sapientiam tuam in corde meo fige.*

*O Domine Jesu Christe (qui sapientia vera es, æterni et Omnipotentis
tui Patris) humilimè tuam oro Divinam Majestatem, expeditum
mihi ut mittere digneris, alicuius pii, sapientis expertique, Philosophi
auxilium, ad illa plenissimè intelligenda perficiendaque, quæ maximi
valoris erunt ad tuam laudem et gloriam amplificandam: Et si
Mortalis nullus iam in terris vivat, qui ad hoc munus aptus sit: vel
qui ex æterna tua providentia, ad istud mihi præstandum beneficium
assignatus fuerit: Tunc equidem humilime, ardentissimè et constan-
tissimè a tua Divina Majestate requiro, ut ad me de cælis mittere
digneris bonos tuos Spirituales Ministros, Angelosque, videlicet Mi-
chaëlem, Gabrielem, Raphaëlem ac Urielem: et (ex Divino tuo
favore) quoscunque, alios, veros, fidelesque tuos Angelos, qui me plene
et perfecte informant et instruunt, in cognitione, intelligentiaque
vera et exacta, Arcanorum et Magnalium tuorum (Creaturas omnes
tuas, illarumque naturas, proprietates, et optimos usus, concernentium)
et nobis Mortalibus scitu necessariorum; ad tui nominis laudem,
honorem, et gloriam; et ad solidam meam, aliorumque (per me,) plurimorum
tuorum fidelium consolationem: et ad Inimicorum tuorum confusionem,
et subversionem. Amen. Fiat Jeovah Zebaoth: Fiat Adonay,*

*fiat Elohim. O beata, et superbenedicta Omnipotens
Trinitas, Concedas mihi (Joanni Dee) petitionem
hanc, modo tali, qui tibi maximè placebit.*

Amen.



*Ab anno 1579. hoc ferè modo: Latinè, vel Anglicè; (ast circa annum 1569
alio et peculiari, particulari modo: interdum pro Raphaële, interdum
pro Michaële) ad Deum preces fundere: mihi gratissimum fuit:
Mirabilem in me faciat Deus Misericordiam suum.*

Amen.



John Dee his Note



Angelus sive In-
telligentia, nunc
toti Mundo prae-
dominens —

Etymologia:
Gratiosa Dei
Afflicta }
Misericore



ANNAEL

4. Angeli praesidentes
4. Cardinibus Caeli:
ut Agrippa notat,
in scala Quater-
narii —

MichaelGabrielRaphaelUrie

1

Etymologiae —

Fortitudo Dei

Prevaescentia —
sive praepotentia —
sive Fortitudo } *Dei*
prævaescens } —

Medicina Dei

Lux Dei

— **⚡⚡ et ⚡⚡**

Anna, et Annah, obsecrantis, et confitentis particula est.
hac ratione, non absurdè innuere videtur,
Orantem et confitentem Deum.

...] *icensia*
...] *rique*

*Ad Deum Omnipotentem Protestatio fidelis:
ad perpetuam rei memoriam Anno 1582.*

O God Almighty, thow knowest, & art my director, and witness herein, That I have from my youth up, desired & prayed unto thee for pure & sound wisdom and understanding of some of thy truths natural and artificial: such, as by which, thy wisdom, goodness & power bestowed in the frame of the word might be brought, in some bountifull measure under the Talent of my capacity, to thy honor & glory, & the benefit of thy Servants, my brethren & Sisters, in, & by thy Christ our Saviour. And for as much as, many yeeres, in many places, far & nere, in many books, & sundry languages, I have sought, & studied; and with sundry men conferred, and with my owne reasonable discourse labored, whereby to fynde or get some ynckling, glyms, or beame of such the forsaid radical truths: But, (to be brief) after all my forsaid endeavor I could fynde no other way, to such true wisdom atteyning, but by thy extraordinary gift: and by no vulgar schole doctrine, or humane Invention. And, Seeing, I have read in thy books, & records, how Enoch enjoyed thy favor and conversation, with Moyses thow wast familiar: And also that to Abraham, Isaac, and Jacob, Josua, Gedeon, Esdras, Daniel, Tobias, and sundry other, thy good Angels were sent, by thy disposition, to instruct them, informe them, help them, yea in worldly and domesticall affaires, yea and sometimes to satisfy theyr desires, doubts & questions of thy Secrets. And furthermore Considering, the Shew stone, which the high preists did use, by thy owne ordering: wherein they had lights and Judgments in theyr great doubts: and considering also that thow (O God) didst not refuse to instruct thy prophets, (then, called Seers) to give true answers to common people of things æconomical, as Samuel, for Saul seeking for his fathers asses being gon astray: and of other things vulgar true predictions, whereby to wyn credyt unto thy waightier affayres: And thinking with my self, the lack of thy wisdom; to me, to be of more importance, then the value of an Asse or two, could be to Cis, (Saul his father): And remembering what good counsaile thy Apostle James giveth, saying, *Si quis autem vestrum indiget sapientia, postulet a Deo, &c.* And that Salomon the wise, did so, even immediately by thy self, attayne to his wonderfull wisdom. Therefore, Seeing I was sufficiently thought and confirmed, that this wisdom could not be come by at mans hand or by humane power, but onely from the (ô God) mediately or immediately) And having allwayes a great regarde & care to beware of the filthy abuse of such as willingly and wetingly, did invoke & consult (in diverse sorts) Spirituall creatures of the damned sort: angels of darknes, forgers & patrons of lies & untruthes: I did fly unto thee by hartly prayer, full oft, & in sundry manners: sometymes crying unto thee, *Mittas lucem tuam et veritatem tuam, que me ducant &c.*, sometymes *Recte Sapere et Intelligere doceto me, Nam sapientia tua totum est quod volo: &c.*, sometymes, *Da verbum tuum in ore meo, et sapientiam*

tuam in corde meo fige ꝑc. And having perceyved by some slight experiens with two diverse persons, that thow hadst a speciall care to give me thy light, and truth, by thy holy and true ministers Angelicall and Spirituall: and at length, hearing of one, (a master of Arts and a preacher of thy word admitted) accownted as a good Seer and skryer of Spirituall apparitions, in Christalline receptacle, or in open ayre, by his practise procured: and trusting to frame him, by my earnest & faithfull prayers unto the (my God) to some my help in my forsayd Studies: tyll, thow (o hevenly father) woldest by thy unsearchable proveydence, send me some apter man or means thereto. Thereuppon trying him and using him, I fownd great diversity betwene his private usuall manner, and intente of practice, and my pure, sincere, devowte, & faithfull prayer unto the onely. And therefore often & fervently I exhorted him to the good; and reprov'd both him, and his ministers, with my no small danger, but that thow (in manner unherd of) didst pitch thy holy tente to my defence, and cumfert, in conflict most terrible: as thow best knowest o God, and I willed him thereuppon to preach thy mercyes, & the verity of the kingly prophet his testimony, *Castra metatur Angelus Domini, in Circuitu timentium eum.* And out of Roger Bachon his boke written *De mirabili potestate Artis et Naturæ*, (where he writeth against the wycked Divil callers) I noted unto him this sentence, *Facilius (sine comparatione a *Deo impetrandum foret, vel a bonis spiritibus, quicquid homini utile reputare ꝑc.* Which my cownsaile he promised me to follow, as thow art witnes, o our true & almighty God. And as thy good spirituall creatures neyther had delight in the man, neyther wold so playnely & preistly give me theyr answers or informations by him, that he might be hable to perceyve the pith therof. So was he at length very unwilling to here him self rebuked for his nawghtynes, and to be barred from the Mysteries of thy truthes understanding; which were the onely things that I desyred, throwgh thy grace, o our most mercifull God. Therefore, as well for a Memoriall answerable to the premisses, as for the better warrant of my Such exercises to be made accownt of, hereafter: (leaving all unto thy infinite mercies, and unsearchable providence,) I have thought it not impertinent, to note downe, even in this place one of the last Actions, which I had with the forsayd preacher: When I made earnest & faythfull petition unto the (o the true and Almighty God) for sending, unto my cumfort & erudition, (yf it were thy blessed will,) thy holy, & mighty Angel Annael: of whome and of all the Hierarchies hevenly all prayse honor & thanks, be rendred unto thy divine majestie: now & ever & worlde without ende. *Amen. Amen. Amen.*

*
*Numquid non est
 Deus in Israël,
 ut eatis ad con=
 sulendum Beelze=
 bub, deum Accaron:
 Reg 4. cap:1.*



Anno 1581 Decembris 22. Mane

Mortlak

AÑAËL

Δ – After my fervent prayers made to God, for his mercifull cumfort and instruction, throwgh the ministry of his holy and myghty Angel, named Anael, (yf it wer his divine pleasure) I willed, the skryer, (named Saul) to loke into my great Chrystaline Globe, yf God had sent his holy Angel Anael, or no: And Saul loking into my forsayd stone, (or Chrystall Globe) for to espie Anael, he saw there ^Δ one, which answered to that name. But being earnestly requested of me to tell the Truthe yf he were Anael, An other did appere very bewtifull, with apparell yellow, glittering, like gold: and his hed had beames like ster beams, blasing, and spredding from it; his eyes fyrie. He wrote in the stone very much in hebrue letters, and the letters seamed all transparent gold: which, Saul was not able eyther presently to reade, that I might write after his voyce, neyther to imitate the letters in short tyme.

Δ Note:
An illuding intruder, even at the first, putting him self, as an angel of light. Take hede allwayes of undue securitie..

A bright star, did go up and down by him.

There appeared allso a white* dog, with a long hed.

And many other visions appeared, with this second: The first being voyded quite away. Thereuppon I sayd, as followeth,

Δ
There appered a great number of dead mens skulls, likewise.

Δ – *In nomine Jesu Christi, Quis tu es?* — He answered
AN – *Potestas omnis, in me sita est.* to Saul his
Δ – *Quæ?* hearing.

AN – *Bona, et mala.*

Δ – Then appeared in the stone, these two letters **M.G.**
I then axing him some questions, *de Thesauro abscondito:*
He answered,

AN – *Ne perturbes: Nam hæ sunt Nugæ.*

And withall appeared many dedd mens skulls, on his left hand.

He sayd to me,

AN – *Ubi est potestas tua?*

Δ – *Cur quæris de potestate aliqua mea?*

AN – *Cur? Signifi, non mihi placet.*

Δ – I, thereuppon, set by him, the stone in the frame: and sayd,

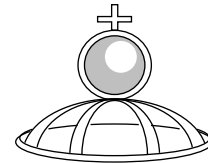

Δ – *An bonus aliquis Angelus, assignatus est huic speculo?*

AN – *Etiam.*

Δ – *Quis?*

AN – **מִיכָאֵל** – he answered, by the shew of these letters in the stone.

Δ – *Bonus ne ille Angelus, de quo in scripturis fit mentio?*

AN – *Maximè.*

Δ – *Fieri ne potest, quod ego eundem videam, et cum illo agam?*

AN – *Ita.* and therewith appeared this character —



Δ – *Quid per hoc, significare velis?*

AN – *Alterius Angeli character est.*

Δ – *Cur hîc, et nunc ostendis?*

AN – *Causam ob magnam.* – Make an ende: It shalbe declared, but not by me.

Δ – By whome then?

Prayer
Fasting

AN – By him that is assigned to the stone: but not, tyll after the feast. And then thow must prepare thyself, to prayer and fasting.

In the Name of God, be secret: and in all thy doings praying, tyll thow hast thy desyre: which shall not be far of.

After Newyeres tyde, Deale, but not on the Sabaoth day.

Pray contynually.

When it shall pleas god, to stir the up, Then procede. In the brightest day, when the Sonne shyneth: In the morning, fasting, begynne to pray.

In the Sonne Set the stone.

Deale both kneeling, and sitting. I have done for this tyme.

My name is ANNAEL.

I will speak ones more to the: and than fare well: for thow shalt not have me any more.

Be not to hasty in wrath.

Δ – Is this, that, you ment to speak?

AN – I : Do good to all men. God hath sufficient for the, and for all men.

Fare well.

Δ – *Gloria patri et filio et spiritui sancto. Sicut erat in principio, et nunc et semper: et in sæcula sæculorum.*

Amen.

Δ – Remember, that diverse other particulars, mowght have byn Noted of this dayes

Action: but these may suffice: And yet it is not to be forgotten, that as he sayd his name was Annael (with a dubble n) so he allso confessed him self to be the same Annaël which is *prepositus orbis veneris*: and allso Chief governor Generall of this period, as I have Noted in my boke of Famous and rich Discoveries.



Consider and
Remember.: }

That this Note, of the Action, (had with holy ANNAEL), is, of prince Befafes, (otherwise called Obelison) accountd as the Prolog of my first boke of mysticall exercises
Anno 1582. Novembris 20. — Vide post.



At Mortlak

In nomine Jesu CHRISTI. Amen.

Anno 1582. Martii die. 10. hora 11 $\frac{1}{4}$ Ante Meridiem. Saturday

△
Note: he had two dayes before made the like demannde and request unto me: but he went away unsatisfied, for his comming was to entrap me, yf I had had any dealing with



wicked spirits as he confessed often tymes after: and that he was set on, &c.

△ – One Mr. Edward Talbot cam* to my howse, and he being willing and desyrus to see or shew some thing in spirituall practise, wold have had me to have done some thing therein. And I truly excused myself therein: as not in the, vulgarly accownted Magik, neyther studied, or exercised: But confessed my self, long tyme to have byn desyrus to have help in my philosophicall studies through the Cumpany and information of the blessed Angels of God. And there=uppon, I browght furth to him, my stone in the frame, (which was given me of a frende) and I sayd unto him, that I was credibly informed, that to it (after a sort) were answerable *Aliqui Angeli boni*: And allso that I was ones willed by a Skryer, to call for the good Angel Anchor, to appere in that stone to my owne sight. And therefore I desyred him to call him: and (yf he wold) Anachor and Anilos likewise, accownted good Angels, for I was not prepared thereunto. *∅c.* He than settled him self to the Action: and on his knees att my desk (setting the stone before him) fell to prayer and entreaty *∅c.* In the mean space, I, in my Oratory did pray, and make motion to god, and his good Creatures for the furduring of this Action. And within one quarter of an howre (or less) he had sight of one in the stone. but he still expected for two more: deeming this to be one of the three (namely Anchor Anachor Anilos). But I then cam to him, to the stone: And after some thanks to God, and Wellcome to the good Creature, used; I required to know his name. And he spake plainly, (to the hearing of E.T.) that his name is URIEL.

△ – Are you one of them (sayd I, John Dee) that are answerable, (uppon due observations performed) to this stone?

URIEL – I am.

△ – Are there any more besyde you?

UR – Michaël and Raphaël. But, *Michaël est princeps in operibus nostris.*

△ – ys my boke, of Soyga, of any excellency?

UR – *Liber ille, erat Adæ in Paradiso revelatus, per Angelos Dei bonos.*

△ – Will you give me any instructions, how I may read those Tables of Soyga?

UR – I can – But *solus Michaël illius libri est interpretator.*

△ – I was told, that after I could read that boke, I shold live but two yeres and a half.

UR – Thow shallt live an Hundred and od yeres.

△ – What may I, or must I do, to have the sight, and presence, of Michael, that blessed angel?

UR – *Præsentialias nostras postulate et invocate, sinceritate et humilitate.*

Et Anchor, Anachor, et Anilos, non sunt in hunc Lapidem Invocandi.

△ – Oh, my Great and long desyre hath byn to be hable to read those Tables of Soyga.

UR – *Hæc maximè respiciunt Michaëlem. Michaël est Angelus, qui illuminat gressus tuos. Et hæc revelantur in virtute et veritate non vi.*

△ – Is there any speciall tyme, or howre to be observed, to deale for the enjoying of Michael?

UR – *Omnis hora, est hora nobis.*

△ – After this, there appered △ in the stone a strange seale, or characterismus of this fashion ensuing:

△:
An illuding spirit straight way intruded him self, and this character: as may appere *Libri Quinti Appendice* where the character is described exactly.

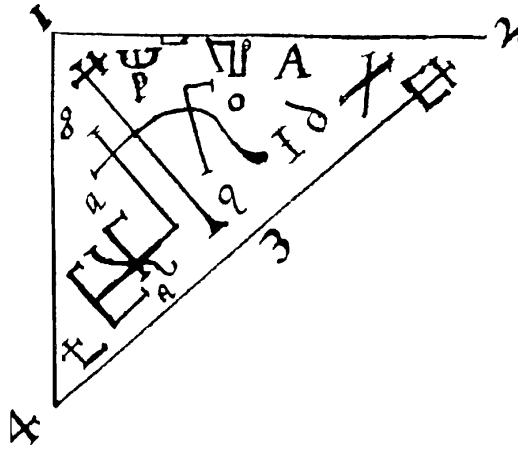

* This was not
True Uriel:
as may appere
A^o 1583: May 5.

Δ – What is the intente, or use of this?

*UR – *Sigillum hoc in auro sculpendum, ad defensionem corporis, omni loco, tempore et occasione: et in pectus gestandum.*

Δ – So we ceased, with thanks to god: and I mused much upon this Action: and layd all up in mynde, and writing.

Δ – *Soli Deo Honor omnis, et gloria.*

Amen.



The same Saturday after none. *Hora. 5.*

Δ – After that Mr. E.T. had called Uriel, and I was come to the stone and had used a short speche of thanks giving to God: I then required some instruction for the purpose of Soyga.

UR – Peace. you must use Michaël.

Δ – I know no meanes or order to use in the invocating of Michaël.

UR – He is to be invocated by certayn of the psalmes of David, and prayers. The which psalmes, are nothing els, but a means unto the seat and Majesty of God: whereby you gather with your selves due powre, to apply your natures to the holy Angels. I mean the psalmes, commonly called the Seven psalmes. You must use pleasant savours: with hand and hart: whereby you shall allure him and wynn him (thorowgh Gods favour) to atteyn unto the thing, you have long sowght for. There must be Conjunction of myndes in prayer, betwyxt you two, to God Continually.

Yt is the wyll of God, that you shold, jointly, have the knowledge of his Angells to_gither.

You had atteyned unto the sight of Michaël, but for the imperfection of Saul.

Be of good Cumfort.

Δ – The chayre cam into the stone againe: and I axed what it ment.

UR – This is a seat of perfection: from the which, things shall be shewed unto the, which thou hast long desyred.

Δ – Then was there a square Table brought into the stone: and I demanded, what that Table betokened.

UR – A Myserie, not yet to be known. These two, shall remayn in the stone, to the sight of all undefyled creatures.

Note.
Δ in this time
there appered
in the stone,
a riche chayre:
and after a little
while, it was
out of sight.

*Erronice,
contra igno=
rantiam meum
vide post.

you must use a fowre square Table, two cubits square: Where uppon must be set *Sigillum Divinitatis Dei*, which is allready *perfected in a boke of thyne: Blessed be God, in all his Mysteries, and Holy in all his works. This seal must not be loked on, without great reverence and devotion. This seale is to be made of perfect wax. I mean, wax, which is clean purified: we have no respect of cullours. This seal must be 9 ynches in diameter: The rowndnes must be 27 ynches, and somewhat more. The Thicknes of it, must be of an ynche and half a quarter, and a figure of a crosse, must be on the back_{side} of it, made thus:

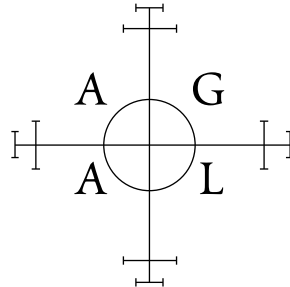

The Table is to be made of swete wood: and to be of two Cubits high with 4 feete: with 4 of the former seales under the 4 feet.

Δ – The fashion of the 4 feet, standing uppon the foresayd rownd seales, was shewed so as the uttermost circle conteyning the letters, did seme to be clean *without the cumpas of the fete, equally rownd about the same fete. And these seales were shewed much lesser than the principall seal. Under the Table did seme to be layd red sylk, two yardes square. And over the seal, did seme likewise red sylk to lye fowrsquare: somewhat broader then the Table, hanging down with 4 knops or tassells at the 4 corners thereof.

Δ Note this point.

Uppon this uppermost red silk, did seme to be set the stone with the frame: right over, and uppon the principall seal: saving that the sayd Sylk was betwene the one and the other.

The Table was shewed to have on the fowre sides of it, *Characters and names, these, that are here in a schedule annexed, in 4 diverse rows.

*Cave: quia
angelus tenebra=
rum se intrusit
hic ut libri
Quinti appendice
apparabit.

UR – The Characters and Words on the sides of the Square Table, are to be written with yellow, made of perfect oyle, used in the church.

Δ – What oyle is that

UR – of That oyle shalbe opened unto you. The oyle, is perfect prayers: of other oyle I have no respect.

We sanctifie, bycause we are holy: and you sanctify bycause of your holines.

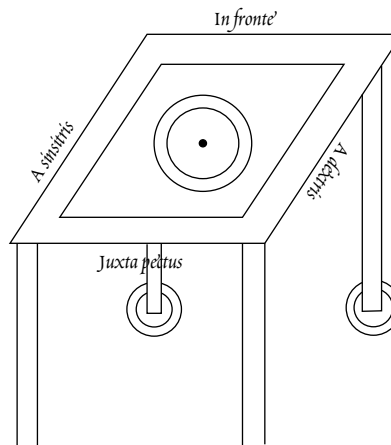

UR – There is a spirit, named Lundrumguffa using you who seketh your destruction, in the hatred of men, in the hurt of thy goods. Discharge him to morrow with Brymstone. He haunteth thy howse, and seketh the destruction of thy dowghter. His pretence was to have maymed the in thy sholder the last night, and long ago. Yf thow do not dischargd him to morrow, he will hurt, both thy wife and thy dowghter.

Δ Note:

* So is it evident who went about to hinder the truth before in the character, and in the border of the Table, falsely cownterfeated &c as it also in the next action may appere.

Saul in danger of being carried away quick.

He is here* now.

Give him a generall discharge from your familie and howse.

He will seke Sauls death, who is accursed.

Δ – I know no means, or art to do this by. For I did burn in flame of Brymstone, Maherion his name and Character, whan I fownd Saul privilie dealing with him (which manner of wicked dealing I had oft forbydden him) and yet he cam after, and wold have carryed Saul away quick: as Robert Hilton, George, and other of my howse can testify.

UR – The cursed will come to the cursed.

Δ – I beseeche you to discharge him: and to bynde him somewhere far of, as Raphael did (for Thobias sake) with the wycked spirit Asmodeus.

UR – But Thobias did his part. Art is vayne, in respect of God his powre. Brymstone is a mean.

Δ – Whan shall I do this?

UR – To morrow at the tyme of prayers.

Δ – *Gloria Patri et filio et Spiritui Sancto sicut, &c. Amen.*



1582 *Martii 11*

Sunday. *a Meridie hora .3a. circiter.*

Δ – Uriel being called by E.T. there appeared one, clothed with a long robe, of purple: all spanged with gold, and on his hed, a garland, or wreath of gold: his eyes sparkling: of whome I axed Whether the characters noted for the Table, wer perfect:

Δ*

Hereby may appere that this wycked spirit foysted in the shew of the fals characters and names before.

He answered,

They are perfect Δ*: There is no question.

Δ – Are you Uriel.

Than presently cam in one, and threw the brave spirit down by the sholders: and bet him mightyly with a whip: and toke all his robes, and apparell of him: and then he remayned all heary and owggly: and styll the spirit was beaten of him, who cam in after him. And that spirit, which so bet him, sayed to the hearing of my skryer, Lo, thus are the wycked skourged.

Δ – Are you Uriel, who speaketh that?

Uri – I am he. Write down and mark this: for it is

Note:
Lundrum=
guffa
skourged
spiritually.

worthy of the Noting.

This was thy persecutor Lundrumguffa. I browght him hither to let the see, how God hath punished thy enemy.

Lo, thus, hath God delt for the: Lo thus have I delt for the:
Thank God.

Δ – blessed be his holy name; and extolled, world with out ende.

E.T – he drew the wycked spirit away, by the leggs, and threw him into a great pitt, and washed his hands, as it were, with the sweat of his own hed: for he seamed to be all in a sweat.

Δ – Here uppon, my skryer saw Uriel go away: and he remayned out of sight a little while. Then he cam in agayn: and an other with him: and jointly these two said to gither, Glorifie God for ever. And than Uriel did stand behinde: and the other did set down in the chayre, with a sworde in his right hand: all his hed glystring like the sonne. The heare of his hed was long. He had wings: and all his lower parts seamed to be with feathers. He had a roab over his body: and a great light in his left hand. he sayd,

Michaël – We are blessed from the begynning: and blessed be the name of God for ever.

Δ – My skryer saw an innumerable Cumpany of Angels about him: And Uriel did lean on the square Table by.

He that sat in the chayre (whom we take to be Michaël) sayd
Than,

—— Go forward: God hath blessed the.

I will be thy Guyde.

Thow shalt atteyne unto thy seching.

The World begynnes with thy doings.

Prayse God.

The Angels under my powre, shall be at thy commanndement.

Lo, I will do thus much for the.

Lo, God will do thus much for the.

Thow shalt see me: and I will be seen of the.

And I will direct thy living and conversation.

Those that sowght thy life, are vanished away.

Put up thy pen.

Δ – So he departed.

Δ – *Gloria, Laus, honor, virtus et Imperium*

Deo immortalī, invisibili, et

Omnipotentī, in sœcula sœculorum.

Amen.

Lundrum=
guffa.



Martii 14. Wensday. mane circa horam 9a.

Δ – Being desirous to procede in this matter, by consent, we bent our selves to the Action. And after that [E T] had called Uriel and saw him, I cam to the desk from my oratorie. There did contynually appeare, the chayre and the Table. I than being affrayde that any other shold come into the stone, in stead of Uriel, did earnestly require the spirituall creature appearing, to shew who he was, and what was his name: At length he answered, and sayde to the hearing of E.T., Uriel is my name, with diverse called *Nariel.

*Agrippa hath so,
cap. 24, Lib. 3,
Occultae Philosophiae

Stay.

Δ – Then he went away, for a while: and cam agayn, and sayd thus,
Ur. – The strength of God, is allwayes with the.

Dost thow know, what thow writest?

Δ – In two senses, I may understand it: eyther that the good Angel ΔGabriel is allwayes with me, thowgh invisibly: or els, that the strength, and mighty hand of God, allwayes is my defense.

Δ -potius erat di-
cendus Michael:
Namen, Gabriel est
Praevalescentia
Dei: et ita, forti-
tudo quidem, sed
altioris gradus.

Ur – *Fortitudo Dei, tecum semper est.*

Δ – He went away agayn, and cam agayn, following or wayting upon an other: and before that other, was a man having his hed all covered with blak. Then he that cam so in the middle, did sit down in the chayre, and spake this worde following:

Mi – Note

Δ – This was Michael, with his sword in his right hand. Then cam Uriel to the man (having his hed all hyd, as it were in a blak hode) and toke of that blak hode: and then lifted up the Table cloth. He looked under it, and put it down againe: and lifted it up again. The man stode still before Michael. Then Michaël rose; and toke of all the mans clothes, and left him, as it were, onely in his shirt. Then Uriel toke a little rownd Tablet, as it were, of the bignes of a sixpence, having two letters in it, thus: and gave it to Michaël. Uriel lifted up the Table cloth: and, from thence, seamed to take apparaile, and put on the man. It semed to be sylk: and very full of wrynckles, or plights. And the man kneeled, and held up his hands. Uriel toke like a lawrell bush, and set upon the mans hed. And than the man kneeled before Michaël. Michaël toke the rownd thing, with the letters: and gave it the man to eat: and he did eat it.



Ur – Lo, things are covered.

Δ – Then he covered the Table and pluckt the cloth over it; down to the grownd, on every side. The man rose up: And Michaël dubbed him on the hed with his sworde. Then the man stode up.

Then the man turned his face toward E.T. the skryer: and the man did resemble me (John Dee) in countenance. And then he turned to Michaël agayn.

Michael wrote upon the mans back, thus,

ANGELVS TVÆ PROFESSIONIS.

*vide Agrippam
de Triplici hominis
custode. Lib.3.
cap.22.*

Δ – Then E.T. asked me, yf there were such Angels of a mans Profession: and I answered yea; as in ^Δ Agrippa and other, is declared.

Mi – Leave your folly: Hold thy peace.

Have you not red, that they that cleave unto God, are made like unto him?

Δ – Yes, forsoth.

Mic – Thow camst hither to lern, and not to dispute.

Laudate Dominum in operibus suis.

Δ – The man kneled down, and so went out of sight.

Mi – He hath eaten strength against trubble: He hath eaten nothing: and in eating, he hath eaten all things. The name [†] NA, be prayded in trubbles.

*† vide Reuclinum
de Verbo Miri
fico, de nomine
NA.*

Δ – Now Michael thrust out his right arme, with the sword: and bad the skryer to loke. Then his sword did seame to cleave in two: and a great fyre, flamed out of it, vehemently. Then he toke a ring out of the flame of his sworde: and gave it, to Uriel: and sayd, thus:

Mic – The strength of God, is unspeakable. Praysed be god for ever and ever.

Δ – Then Uriel did make cursy unto him.

Mi – After this sort, must thy ring be: Note it.

Δ – Then he rose, or disapeared, out of the chayre, and by and by, cam again, and sayde, as followeth.

Mi – I will reveale the this ring: which was never revealed since the death of Salomon: with whom I was present. I was present with him in strength, and mercy.

Lo, this it is. This is it, wherewith all Miracles, and divine works and wonders were wrowght by Salomon: This is it, which I have revealed unto the. This is it, which Philosophie dreameth of. This is it, which the Angels skarse know. This is it, and blessed be his Name: yea, his Name be blessed for ever.

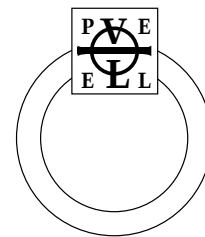

Δ – Then he layd the Ring down upon the Table: and sayd, Note.

Δ – It shewed to be a Ring of Gold: with a seale graved in it: and had a rownd thing in the myddle of the seale and a thing like an V, through the top of the circle: and an L, in the bottome: and a barr cleane through it: And had these fowre letters in it, P E L E.

*vide Reuclini
librum de verbo
mirifico de
Nomine PELE.*

After that, he threw the ring on the borde, or Table: and it semed

to fall through the Table and then he sayde, thus,

Mi – So shall it do, at thy commandment.

Without this, thou shalt do nothing.

The Use of the Ring.

Blessed be his name, that compasseth all things:

Wonders are in him, and his Name is WONDERFULL:

His Name worketh wonders from generation, to generation.

Δ – Then he went away: and came in again by and by.

Mi – Note.

Δ – Then he brought in the Seale, which he shewed the other day: and opened his sworde, and bad the skryer, reade, and he red,

EMETH.

Then the sword closed up again: and he sayde,

Mi – This I do open unto the, because thou mervayledst at SIGILLUM DEI. This is the Name of the Seale: which be blessed for ever. This is the seale self. This is Holy: This is pure: This is for ever. Amen.

Δ – Then the seale vanished away. And I sayd to my frende (the skryer) In dede, this other day, I considered diverse fashions of the seal: and I found them much differing, one from an other: and therefore I had neede to know, which of them I shall imitate: or how to make one perfect of them all.

Mi – Downt not for the making of it: for God hath perfyted all things. Ask not the cause of my absence, nor of my apparell: for that Mysterie, is known to God. I have no cloathing, as thou thy self Shalt see. I am a spirit of Truth, and Vertue. Yea you shall see me in Powre, and I will viset you in HOPE.

Bless you the Lorde, and follow his wayes, for ever.

Δ – Then he went away: and Uriel followed him.

And then I sayde to my skryer: It were good, we had ever some watch word, when we should not Loke for any more matters at their hands, every tyme of their visitting of us. Whereuppon, (unlooked for, of us,) he spake again.

Mi – We lead tyme, Tyme leadeth not us:

Put up thy pen.

The Name of God, be blessed for ever.

Δ – Then they lifted up their hands to heavenward (which heven, appeared also in the stone) and turned toward us, and sayd,

Valete.:

Δ – So they departed: and at their going, the chayr, and the Table, in the stone, did seme to shake.

Δ – *Soli Deo omnis honor*

Laus et Gloria .:

Amen.

*De sigillo Emeth,
vide Reuclini Artem
Cabalisticam, lib.3. et
Agrippam lib. 3.
Cap.11.*



Martii 15. Thursday. Hora 1¼ a meridie.

Δ – After [E T] his calling into the stone, appeared a tall man, with a sceptre (very great) of gold, glittering. His body all red: and out of his hed, did shote out beames of light, like the sonne beames.

Δ – I being desirous, to know who he was, and his name, I requested him earnestly thereto. But he answered, as followeth,
Invocate nomen Domini, et agnoscetis eum.

Δ – Then I prayed the psalme, *Deus misereatur nostri, et benedicat nobis &c.* After that, he sayd,
I am mighty.

Δ – Bycause he delayed to declare his name, [E T] the skryer did require him, in the name of God the father, Jesus Christ his sonne, and of the holy ghost, to express his name: and he answered in speche.
So I will by and by.

Δ – Then he seamed to take from his hed little bright sparcks, like little candells endes: and to stick them abowt the chayre: and he went rownd abowt the chayre: and than he spake, as followeth,
I am mighty, and working wonders: I am SALAMIAN.

SALAMIAN

Δ - of Salamian you may rede, in the call, *Diei Dominicae in Elementis Magicis Petri de Abano*, there called Salamia.

I rule in the hevens, and beare sway uppon erth in his name, who be blessed for ever. Thow doost dowt at me. I am the servant of God, in his light: I serve him. I say, I serve him, with feare and reverence. My name is SALAMIAN: Mighty in the Sonne, worker of wordly actions, as well internall, as externall: known unto God: whose name I know, and bless for ever.

Δ – Then appeared a big flame of fyre by him in the ayre.

Sal – Thow knowest not, or thow wilt not know, that Mamon, with his servants, are present abowt the: whose presence doth hinder the presence of the vertues Adonay our comming. Blessed be God, in the highest.
Amen.

Δ – He toke the forsaide flame of fyre, and flung it up unto the heaven ward.

Mamon. Sal – Mamon is a king whome God hateth: whose sect, contynually tempt, provoke and stir up wickednes, against the Lord, and against his annoynted. But he dyeth: blessed be God for ever. Drive him away.

Δ – It is incomparably more easy for you to do. And as for my parte, I fele neyther in body, nor sowle, any token of his presence or working. Thereuppon he caused the whole chamber (which we were in) to appere very playnely in the stone: and so there shewed a great cumpany of wycked spirits to be in the chamber: and among them, one, most horrible and grisely thretting, and approaching to our heds: and skorning and gnashing at us.

Sala – God determines his mysteries, by Arte and vertue.

Δ – Then he willed me very egerly, to drive them away. And I prayed fervently. And there seamed One to come into the stone, which had very long armes: and he drave them away courragiously: And so they were driven away.

After that presently, cam one into the stone, all white.

Salamian reached this white one a Cup.

The white man held up the Cup: and sayd, as followeth,

——— Lo, this is my name.

Raphaël

God shall bless you. Fear not: your faithfullness provoketh me to tell my name, and this it is: (putting furth the Cup again) for, I am called *Medicina Dei*. I will shew the, and I will shew you, the Angel of

De OCH vide in
libello Arbatel
in ☉

your Direction, which is called OCH.

Δ – This name he spake: he shewed it allso on the Table (before him) written.
Raph – He is mighty in the sonne beames: He shall profit the hereafter.

Δ – Then cam in an other, and sat down in the chayre: and he sayde, as followeth,

The strength of God liveth: and God raigneth for ever.

I am Fortitudo Dei.

Δ – Why, then, you are Gabriel: and I toke you hitherto to be Michaël.
How shall I then amend my boke, in respect of your name, allwayes before, written Michaël?

[For. Dei] – What thow hast written, that hast thow written: and it is true.

Write down this name. POLIPOS.

Dost thow understand it?

Δ – No, God knoweth.

[For. Dei] – When that day commeth, I will speak with the: yf thow observe that which I have * commanded the.

As truely, as I was with SALOMON, so truely will I be with the.

Δ – Then cam in an other, whom we toke to be Uriel: for he went allso, as he was wont, and leaned at the Table.

[For. Dei] – Search for wisdome and lerning, and the lord will deliver it unto you.

Δ – I wold to god, I knew your name truely, or what peculier letter I might set for you, to Note your words and Actions by.

[For. Dei] – Name I have none, but by my office.

SALAMIAN cam not hither, but by me.

He is a mighty Prince, governing the hevens, under my powre.

This is sufficient for thy Instruction.

I was with Salomon, in all his works and wonders:

and so was this, whome God had appointed unto him.

The Divines know his name: and he is not hidden from the face of the erth: His name is written in the boke which lyeth in the wyndow.

Δ – Do you mean Agrippa his boke? And is it there expressed by the name SALAMIAN?

[For. Dei] – I have sayde.

Δ – What order will you appoint unto us two, in respect of our two beings to gither? My frende here, may have other intents and purposes of his affayres, then will serve me, for his ayde having in these Actions.

[For. Dei] – Joyne in prayers. For God hath blessed you: Downt not. Consider these mysteries.

Δ – Then they in the stone used talk to gither: but not well to be discerned of the eare of [E.T]

At length [F.D] talked very much, and spedily to [E.T] and disclosed unto him (which he expressed not to me, at the stone but afterward) all the manner of the practise, and the circumstance about the Action intended, with the Gold lamin, the ring, the Seales &c. And after I had spoken somewhat, in requesting him, to shew me the manner, How I shold artificially prepare every thing spoken of, he sayd,

[F.D]...

Δ*
Perchance he
meaneth the
cownsayle of
Annael: before
specified.

Δ - It is in *Elementis
Magicis Petri de Abano*
printed with *Clavis
Agrippae*, which
was in my oratorie
almost under my
wyndow.

[The top third of a page is missing here.]

Write — God will be revenged uppon Saul: for he hath abused his names in his Creatures.
He hath sinned agaynst kinde. His punishment is great: and so I ende.

[...] Blessed be God, who revealeth all Mysteries, &c.
I am strength in nede.
And Lo, here is Medicine for the sore.
We bless the Lord: We govern the erth, by the societie of Gabriel:
whose powre, is with us: but he not here. &c.
Use Patience.

Ur – I lived with Esdras: I lived in him, in the lord, who liveth
for ever.

Raph – I lived with Tobie: Tobie the yonger.

Δ – This was the white creature, that spake this.

[F.D] – We live in the Lorde: who be prayed for ever.

Δ – I stode silent a good while.

[F.D] – What wilt thou?

Δ – I did attend, what you wold say.

[F.D] – I have sayd.

Δ – I have byn long at this tyme, in my dealing with you. I trust,
I do not offend you therewith. But, for my parte, I could finde in
my hart to contynue whole dayes and nights in this manner of doing: even
tyll my body shold be ready to synk down for wearines, before I wold
give over. But I feare, I have caused wearines to my frende here.

[F.D] – In vertue is no wearines.

Δ – Now he stode up, out of his chayr: and he, and they all, jointly
blessed us, stretching theyr hands toward us, Crossingly. And so
they went away. The Table and the chayre remayned
and the glyttring sparckles, or drops of streaming little
lightes were of the chayre immediately.

Δ – Glorie, thanks, and honor
be unto the Almighty Trinitie.

Amen.



[Elias Ashmole's Note:]

Mysteriorum Liber Primus, tooke
ending here (as I conceive) after which
followes *Mysteriorum*⁺ *Liber*
secundus, but the begining thereof
is utterly perished.

⁺So it appears to be by divers
Quotations in the following Books.

Liber Primus – Notes and Translations

(Notes and translations copyright © 1999 Raymond and Susan Drewry. Page numbers refer to Clay Holden's transcription; taking Page 1 as the first page of Dee's text after the Anno 1581:1582 Mysteriorum Liber Primus title page.)

Page 1

Praeter alias meas extemporaneas preces, et ejaculationes ad Deum vehementiores: Haec una, maxime usitata fuit
Oratio mea Matutina, Vespertinaque: pro Sapientia.

Among my other extemporaneous prayers and most fervent outpourings to God: this one was most customarily used. My Morning and Evening Prayer: for wisdom.

In nomine Dei Patris, Dei Filii, Dei Spiritus Sancti Amen

In the name of God the Father, God the Son and God the Holy Ghost. Amen

“In Nomine Dei Patris...”

Dee implies (here and elsewhere) that he started all his Actions with the prayers on this page. This particular phrase is the standard Western Christian formula for marking the ritual start of an Office, Service, or other ceremony or rite. It is also used within a service to mark a change of focus or as a section boundary. As an example of the former, it is used at the start of the Mass, and after it is said the priest is instructed to ignore anything else going on in the church, even the elevation of the Host at another Mass. As an example of the latter, it is used in the Anglican rite to introduce the sermon or homily.

Omnipotens, Sempiterna, vere, et vive Deus, in adiutorium meum intende: Domine

Dominantium, Rex Regum, Jeovah Zebaoth, ad adiuvandum me festina:

Gloria Deo, Patri, Filio, et spiritui Sancto: Sicut erat in principio, et nunc, et semper et in saecula saeculorum: Amen.

Almighty, Everlasting, True and Living God, make haste to deliver me. Lord of Lords, King of Kings Jehovah Zebaoth, make haste to help me.

Glory be to God, Father, Son and Holy Ghost: As it was in the beginning, is now and forever, world without end: Amen.

Translator's Note: 'semper et in saecula saeculorum' is generally given in English translations as "forever, world without end" or "for ever and ever." Literally, it is "always, unto an Age of Ages", and is done in imitation of a Hebrew idiom.

“Omnipotens...Amen”

Christian communal life (monastic and secular) was, until the Reformation, built around the Daily (or Divine) Office, a series of eight liturgical services centered on the recitation of psalms and prayers. It was also common for individuals to structure their private devotions around parts of the Office.

Almost every service of the Daily Office opened with the psalm verse “Deus ad adiuvandum me festina”, followed by the lesser doxology. (The exception was Matins, the first service of the day,

where “Deus ad adiuvandum” usually came as the second element.) See the notes below for details of the psalm and the doxology.

The elaboration of the simple biblical “God” to a longer list of names and attributes is a cabbalistic practice, detailed by Reuchlin and Agrippa. See, for example, the works cited in the discussions of PELE and NA later in Liber Primus.

The daily office ended with a simple “Benedicamus Domino” (“Let us bless the Lord.”) Every Action in Liber Primus is closed with a more elaborate blessing (e.g. the doxology, *Soli Deo honor omnis*, “Glorie, thanks, and honor be unto the Almighty Trinitie”, etc.)

Thus, Dee not only marked out his ritual time and space using the same formula a religious service would use (see note on “In nomine” above), but also began the Actions with the standard introductory formula from the daily cycle of prayer and devotion, and ended each one with an elaboration of the traditional closing.

“Ad adiuvandum me festina” – Ps 69:2 (Vulgate), Ps 70:1 (English Bibles)

Vulgate ex Septuaginta: Deus in adiutorium meum intende Domine ad adiuvandum me festina;

Vulgate ex Hebraeo: Deus ut liberares me, Domine ut auxiliaberis mihi festina

BCP: Haste thee, O God, to deliver me: make haste to help me, O Lord.

Geneva Bible: O god, haste thee to deliver me: make haste to help me, O Lord.

KJV: Make haste, O god, to deliver me; make haste to help me O LORD

“Gloria...”

This is the short doxology, generally used after psalms, hymns, and canticles. Generally, though, it begins “Gloria Patri” rather than “Gloria Deo, Patri.”

Recte sapere, et intelligere doceto me, (o rerum omnium Creator,) Nam Sapientia tua, totum est, quod volo: Da verbum tuum in ore meo, (o rerum omnium Creator,) et sapientiam tuam in corde meo fige.

Teach me to know aright and to understand (O Creator of all things) for thy wisdom is all that I desire. Give thy word in my mouth (O Creator of all things) and fix thy wisdom in my heart.

“Fige”

Note that *figo* is also the word used for driving nails.

O Domine Jesu Christe (qui sapientia vera es, aeterni et Omnipotentis tui Patri) humilime tuam oro Divinam Majestatem, expeditum mihi ut mittere digneris, alicuius pii, sapientis expertique, Philosophi auxilium, ad illa plenissime intelligenda perficiendaque, quae maximi valoris erunt ad tuam laudem et gloriam amplificandam: Et si Mortalis nullus iam in terris vivat, qui ad hoc munus aptus sit: vel qui ex aeterna tua providentia, ad istud mihi praestandum beneficium assignatus fuerit: Tunc equidem humilime, ardentissime et constantissime a tua Divina Majestate requiro, ut ad me de caelis mittere digneris bonos tuos Spirituales Ministros, Angelosque, videlicet Michaellem, Gabrielem, Raphaellem ac Urielem: et (ex Divino tuo favore) quoscunque, alios, veros, fidelesque tuos Angelos, qui me plene et perfecte informet et instruant, in cognitione, intelligentiaque

vera et exacta, Arcanorum et Magnalium tuorum (Creaturs omnes tuas, illarumque naturas, proprietates, et optimos usus, concernentium) et nobis Mortalibus scitu necessariorum; ad tui nominis laudem, honorem, et gloriam; et ad solidam meam, aliorumque (per me,) plurimorum tuorum fidelium consolationem: et ad Inimicorum tuorum confusionem, et subversionem. Amen.

O Lord Jesus Christ (who art the true wisdom of thine eternal and almighty Father), I most humbly beseech thy Divine Majesty, that thou deignest to send me the speedy aid of some pious, wise and expert philosopher for the complete understanding and accomplishing of that which will be of the greatest worth for the increase of thy praise and glory: And if there should be no Mortal now living on earth who might be fitting for this gift, or who by thy divine providence might be assigned to the fulfillment of this my prayer, then equally most humbly, most ardently and most constantly, I request from thy Divine Majesty that thou deignest to send to me from the heavens thy good Spiritual Ministers and Angels, which is to say, Michael, Gabriel, Raphael and Uriel: and (out of thy Divine favor) whatever other true and faithful of thy Angels, who might completely and perfectly inform and instruct in the knowledge and in the true and exact intelligence of thy Secrets and Miracles (concerning all thy Creatures and their natures, properties and best uses) the understanding of which is necessary to us Mortals; to the praise, honor and glory of thy name and to my thorough consolation and (through me) that of many others of thy faithful, and to the confusion and subversion of thine enemies. Amen.

“Spirituales”

“Spirituales” has senses of form (as in spiritual beings – i.e. Angels) and function (as in ‘Spiritual Father’, when applied to a priest.)

Fiat Jeovah Zebaoth: Fiat Adonay,
Fiat Elohim. O beata, et superbenedicta Omnipotens
Trinitas, Concedas mihi (Joanni Dee) petitionem hanc, modo tali, qui tibi maxime placebit.
Amen

Let it be so, Jehovah Zebaoth: Let it be so Adonai, let it be so Elohim. Oh Holy and Surpassingly Blessed Almighty Trinity, May you grant me (John Dee) this petition in the way that is most pleasing to you. Amen.

“Fiat”

“Let it be so” is one translation of “Fiat” which may have many translations. This one was chosen for its resemblance to “Fiat Lux” commonly translated “Let there be light”. Alternative translations for “Fiat” are “May it be so” and “Make it so.”

Ab anno 1579. hoc fere modo: Latine, vel Anglice; (ast circa annum 1569 alio et peculiari, particulari modo: interdum pro Raphaele, interdum pro Michaele) ad Deum

preces fundere: mihi gratissimum fuit:
Mirabilem in me faciat Deus Misericordiam suam.
Amen.

From the year 1579, it was done in this way: in Latin and in English; (but around the year 1569 in another and peculiar, particular way: sometimes for Raphael, sometimes for Michael. To pour prayers out to God: this was most pleasing to me. May God bring forth his marvelous mercy in me. Amen.

John Dee His Note (Page 2)

Angelus sive Intelligentia, nunc toti mundo praedominans
The Angel or Intelligence now ruling over the whole world.

“Intelligentia”

In a theological sense *intelligentia* is a ‘a non-corporeal Being or Intelligence’, and is commonly used for angels and spiritual beings. Agrippa, Ficino, and Aquinas use it in this sense. ‘Intelligentia’ can also be a ‘rational activity, rational comprehension’, in a more philosophical than theological way (also used by Aquinas and various neoplatonizing Christians.) Here, it is easy to opt for the former meaning, though in Liber Tertius the choice is not so clear.

“Annael praedominans”

Oddly enough, Trithemius in his De Septem Secundeis (also called Chronologia Mystica) says that Gabriel is the Angel currently (in 1582) presiding over the world. Annael is problematic in other ways as well. (See below.)

Etymologia: {Gratiosa/Afflicta} misericors Dei

Etymology: The Gracious/Afflicted Merciful ... of God.

Translator’s Note: This is a little problematic, since there is no noun here. (The four other Angels in the Note are all described with nouns.) It could be, for instance, the “merciful nature” or “merciful things” of God. “Gratiosa/afflicta” can be explained in Christian terms, in which God’s mercy is both gracious (in many senses of the word) and suffering (because of the Passion and Death of Christ.)

4 Angeli praesidentes 4 Cardinibus Caeli: ut Agrippa notat in scala Quarternarii.

4 Angels presiding over the 4 cardinal points of Heaven, as Agrippa notes in his scale of fours.

“scala Quarternarii”

Note that this reads “scale of fours”, not “scale of four”. This is translated “The Scale of the Number of Four” in James Freake’s edition of 1651. The table can be found in Agrippa, De Occulta Philosophia, II.7

Etymologiae --

Etymologies --

Fortitudo Dei

The Strength of God

Praevalescentia -- sive praepotentia -- sive Fortitudo Praevalesecens -- Dei

The growing strong -- or the great power -- or the Prevailing Strength -- of God

Medicina Dei

The Medicine of God

Lux Dei

The Light of God

Anna, et Annah, obsecrantis, et confitentis particula est. Hac ratione, non absurde innuere videtur, Orantem et confitentem Deum.

Anna, and Annah, is a particule of one beseeching or acknowledging. By this reason, it is seen, not absurdly, to signify praying to and acknowledging God.

Translator's Note: "Confiteor" is more commonly translated "confess", as in "confess the strength of Christ crucified". "Acknowledge" was chosen instead as it might be less ambiguous to a modern reader.

"ratione"

For expanding "roe" to "ratione", see [Dizionario di Abbreviature latine ed italiane](#). Other editors have taken the text as "coe", which has no satisfactory expansion.

First Page of text after prayer (Page 3)

Ad Deum Omnipotentem Protestatio fidelis:

ad pertetuum rei memoriam Anno 1582

A faithful declaration to Almighty God for the perpetual memory of the event(s) in the year 1582.

Translator's Note: In more modern English, this might read "I swear to Almighty God that this is an accurate account of what happened in 1582". Also, the phrase "Protestatio fidelis" might make one think of Dee as a faithful Protestant, but this is a mere hint or interpretation and not a literal rendering.

Si quis autem vestrum indiget sapientia, postulet a Deo etc.

For if any of you is in need of wisdom, let him ask of God, etc.

"Si quis..." – James 1:5

The text in the microfilm of Sloane 3188 may have a dot over the final "a" or it may not. If it does, this would then read "sapientiam", which is also grammatically correct, and the reading in the Vulgate.

Vulgate: si quis autem vestrum indiget sapientiam postulet a Deo qui dat omnibus affluenter et non inproperat et dabitur ei.

KJV: If any of you lack wisdom, let him ask of God, that giveth to all *men* liberally, and upbraideth not; and it shall be given him.

Geneva Bible: If any of you lacke wisdom, let him aske of God, which giveth to all men liberally, and reprocheth no man, and it shall be given him.

Mittas lucem tuam et veritatem tuam, que me ducant etc.

Send forth thy light and thy truth, which may lead me, etc.

“Mittas lucem...” Psalm 42:3 (Vulgate), Psalm 43:3 (English Bibles)

Though this echoes Psalm 42:3 in the Vulgate (Ps 43:3 in the English Bibles and Psalter), it is not an exact quotation.

Vulgate ex Septuaginta: emitte lucem tuam et veritatem tuam ipsa me deduxerunt et adduxerunt in montem sanctum tuum et in tabernacula tua

Vulgate ex Hebraeo: mitte lucem tuam et veritatem tuam ipsae ducent me et introducent ad montem sanctum tuum et ad tabernaculum tuum

BCP: Oh sende out thy light and thy trueth, that they may leade me: and bring me unto thy holy hill, and to thy dwelling.

Geneva Bible: Sende thy light and thy trueth: let them leade me: let then bring me unto thine holy Mountaine and to thy Tabernacles.

KJV: O send out thy light and thy truth: let the lead me; let them bring me unto thy holy hill, and to thy tabernacle.

Recte Sapere et Intelligere doceto me, Nam sapientia tua totum est quod volo, etc.

Teach me to know well and to understand for thy wisdom is all that I desire, etc..

Da verbum tuum in ore meo, et sapientiam tuam in corde meo fige, etc.

Give thy word in my mouth and fix thy wisdom in my heart.

Translator’s Note: “Give thy word in my mouth, and thy meditation in my heart” is used by some traditionally-minded Episcopalian and Anglican priests before officiating at Holy Communion.

Page 4

Castra metatur Angelus Domini, in Circuitu timentium eum,...

The Angel of the Lord measures out his camp, encircling those that fear him,

“Castra metatur” – Psalm 33:8 (Vulgate); Psalm 34:7 (English)

Ex Septuaginta: vallabit angelus Domini in circuitu timentium eum et eripeit eos

Ex Hebraeo: circumdat angelus Domini in gyro timentes eum et eruet eos.

BCP: The Angel of the Lord tarieth round about them that feare him: and delivereth them.

KJV: The angel of the LORD encampeth round about them that fear him, and delivereth them.

Geneva Bible: The Angel of the Lord pitcheth round about them, that feare him, and deliuereth them.

Dee’s version is slightly different from either of these. “Metatur” has the sense of surveying or measuring out an area, unlike either ‘circumdat’ or ‘vallabit.’ The more precise word is consonant with the angelically directed mathematical construction and subdivision of the *Sigillum Aemeth* in the second book. It could also be that Dee the mathematician found the surveying term more congenial than the less technical wordings in the Vulgate.

De mirabili potestate Artis et Naturae.

Concerning the miraculous power of Art and Nature.

Facilius (sine comparatione) a Deo impetrandum foret, vel a bonis spiritibus, quicquid homini utile reputare etc.

Whatever is considered useful to man is more easily (immeasurably so) entreated from God, or from good spirits, etc.

“Facilius....”

The Bacon work is variously titled Epistola Fratris Rogerii Baconis de Secretis Operibus Artis et Naturae, et de Nullitate Magiae or Epistola Rogerii Bacon de Potestae Artis et Naturae. Dee gives yet a third notion of the title. (I have picked and chosen the manuscript variants that most closely match Dee’s text. One of Dee’s copies seems to have embodied a state of the text not otherwise known – see Roberts and Watson, p. 62, and their notes on catalog numbers D4 and DM163. One wonders whether Dee’s text was lacking *de Nullitate Magiae* -- “on the Nullity of Magic”, or whether he suppressed the thought.)

Et adhuc erratur, quando per invocationes, et deprecationes, et sacrificia nituntur homines eos placare et adducere pro utilitate vocantium; facilius enim sine comparatione a Deo impetrandum foret, vel a bonis spiritibus, quicquid homini debet utile reputare.

And still it is mistaken, when men strive, through invocations and prayers and sacrifices, to please and persuade them for the benefit of the callers; for it is incomparably easier to obtain from God, or from good spirits, anything which ought to be deemed useful for man.

Whitby (p 202-23) cites a 1659 English translation Frier Bacon his Discovery of the Miracles of Nature, and Magick, about which he notes “This edition bears the notice on the title-page that it has been ‘faithfully translated out of Dr. Dee’s own copy, by T.M.’” The translation could just as well have been made out of the Froben edition of 1618, which also claims to be taken from Dee’s copy – see Roberts and Watson above.

without all question the way is incomparable more easie to obtain any thing, that is truly good for men, of God, or good angels, then of wicked Spirits” (pp.3-4)

Numquid non est Deus in Israel, ut eatis ad consulendum Beelzebub deum Accaron.

Reg. 4 cap. 1

Is it not because there is not a God in Israel, that you go to consult Beelzebub, the god of Accaron? II Kings , 1:3

“numquid...” – IV Malachim 1:3 (Vulgate); II Kings 1:3 (KJV, Geneva)

Vulgate: numquid non est Deus in Israhel ut eatis ad consulendum Beelzebub deum Accaron
KJV: Is it not because there is not a God in Israel, that ye go to enquire of Baal-zebub the god of Ekron?

Geneva Bible: Is it not because there is no God in Israel, that ye goe to enquire of Baal-zebub the god of Ekron?

Dee is just adding biblical support to the Bacon text – the children of Israel only consult a false god because they no longer know their own God.

Various editions of the Vulgate call the book of Kings ‘Malachim’ (borrowed from the Hebrew) or ‘Regum’ (more strictly Latin.)

Page 5

Anno 1581 Decembris 22. Mane

1581, December 22. In the morning.

In Nomine Jesu Christi, Quis tu es?

In the name of Jesus Christ, who are you?

Potestas omnis, in me sita est.

All power is centered in me.

Quae?

Which?

Bona, et mala.

Good, and Evil.

“Bona, et mala”

Genesis 3:5

Vulgate: et eritis sicut dii scientes bonum et malum

Geneva Bible, KJV: and ye shall be as gods, knowing good and evil

de Thesauris absconditis:

concerning the hidden Treasure:

Ne perturbes: Nam haec sunt Nugae.

Be not troubled: for these are trifles.

Ubi est potestas tua?

Where is your power?

Cur quaeris de potestate aliqua mea?

Why do you inquire of any power of mine?

Cur? Significari, non mihi placet.

Why? Show it, I am not pleased.

“Cur? Significari...”

By attempting to turn divert Dee’s questions back on to Dee himself, and by challenging Dee’s authority, Annael is conforming to the standard recorded behavior of summoned beings from classical times through to the 19th century. Dee does not succumb to the diversion, or give in to the threats.

An bonus aliquis Angelus, assignatus est huic speculo?

Is some good Angel assigned to this mirror?

Etiam.

Even so.

Quis?

Who?

Bonus ne ille Angelus, de quo in scripturis fit mentio

Is it not that Good Angel of whom mention is made in the scriptures?

“in scripturis fit mentio”

There are many scriptural references to Michael the Archangel , e.g. Jude I:9 and Rev. 12:7 . The Michael referred to in the Book of Daniel 10:13, 10:21 and 12:1 is also probably the Archangel, though he is referred to only as a “great prince” (KJV) or “unus de principibus primis” (Vulgate.) See following note on “princeps.”

Maxime.

Most Certainly.

Fieri ne potest, quod ego eundem videam, et cum illo agam?

Can it be that I might see that one and deal with him?

“agam”

"Do" or "have doing" or "traffic" are all possible translations for “agam.” Dee uses “deal” to describe his actions with spirits in other places, e.g. “I have byn long at this time, in my dealing with you” at the end of the last Action in Liber Primus.

Ita.

Yes

Quid per hoc, significare velis?

What do you wish to signify through this?

Alterius Angeli character est.

It is the character of another Angel.

Cur hic, et nunc ostendis?

Why do you show this here and now?

Causam ob magnam.

For a great purpose.

Page 6

“Pray contynually”

I Thessalonians V:17

Gloria patri et filio et spiritui sancto, sicut erat in principio et nunc et semper: et in saecula saeculorum. Amen

Glory be to the father and to the son and to the holy ghost as it was in the beginning, is now and forever world without end. Amen

“Gloria patri...”

This is exactly the lesser doxology, without the extra *Deo* between *Gloria* and *patri*. See the note on the introduction to the opening prayer.

Annael....praepositus orbis veneris

Annael.....in charge over the sphere of Venus

Translator’s Note: “Praepositus” is literally ‘placed over’ or ‘set over’, but can also mean a chief or commander. In classical Latin, it is used for the governor of a province.

Annael

See Trithemius, De Septem Secundeis §2.

In Agrippa, De Occulta Philosophia, this Angel is named Haniel. (See for instance the tables in II.10 and II.12, and III.10 'Of Divine Emanations'.)

Annael/Haniel/Anael is problematic in both primary and secondary sources. The attribution to Venus is constant in Agrippa, and seems likely in Picatrix III.ix.23, but the spelling, derivation, and meaning of the name seem obscure. A Dictionary of Angels claims that Annael and Haniel are synonymous, but gives very different descriptions under the two names. See also the difficulties with the etymology given in "John Dee His Note" above.

Anno 1582 Novembris 20. -- Vide post

In the year 1582, November 20 -- see what follows

Page 7

In nomine Jesu Christi Amen

In the name of Jesus Christ Amen

Marti die .10. hora 11 ¼ Ante Meridiem

In the year 1582 the 10th day of March, 11:15 am.

Aliqui Angeli boni

Some good Angels

Michael est princeps in operibus nostris

Michael is first in our works

Translator's Note: "Princeps" is a heavily loaded word -- "first (in time or in precedence)", "pre-eminent", "leader", "originator", "prince", are all possible renderings.

"Soyga"

Could be seen as 'αγιος (Greek for "holy") backwards.

"my boke, of Soyga"

Dee's Book of Soyga is probably Sloane 8, with the inscription "Aldaraia, sive Soyga vocor"; this *incipit* matches Ashmole's description of Dee's book. It contains astrology and demonology; the 'tables' which so interested Dee are algorithmically generated, and of unknown use. They could be cryptographic, for instance, or for use in generating magical apparatus or rites. Please see Jim Reeds' paper for details.

Ur: Liber ille, erat Adae in Paradiso revelatus per Angelos Dei bonos.

That book was revealed to Adam in paradise by the good Angels of God.

Ur. ...solus Michael illius libri est interpretator.

Only Michael is the interpreter of that book.

Ur. Praesentias nostras postulate et invocate, sinceritate et humilitate. Et Anchor, Anachor, et Anilos, non sunt in hunc Lapidem Invocandi

Ask and invoke our presences with sincerity and humility. And Anchor, Anachor, and Anilos are not to be invoked into this stone.

Ur. Haec maxime respiciunt Michaellem. Michael est Angelus, qui illuminat gressus tuos. Et haec revelantur in virtute et veritate non vi.

These things most of all are the concern of Michael. Michael is the Angel who illuminates your steps. And these things are revealed in virtue and truth, not force.

Translator's Note: Here *vis* is "force", to avoid confusion with *fortitudo* ("strength.")

Ur. Omnis hora, est hora nobis.
Every hour is our hour.

(in margin) Libri Quinti Appendice
In the Appendix of the fifth book

Page 8

Sigillum hoc in auro sculpendum ad defensionem corporis, omni loco, tempore et occasione: et in pectus gestandum.

This seal is to be graven in gold for the defense of the body at every time, place and occasion: and is to be worn on the breast.

Δ: Soli Deo Honor omnis, et gloria. Amen.
To God alone all honor and glory. Amen.

Hora 5
At the Fifth Hour

"the Seven psalmes"

The seven penitential psalms are
(Vulgate) 6, 31, 37, 50, 101, 129, 142
(English) 6, 32, 38, 51, 102, 130, 143

Page 9

Sigillum ~~Divinitatis~~ Dei
Seal of the ~~Divinity~~ of God

(in margin) Erronice contra ignorantiam meam vide post
Mistakenly, against my ignorance. see what follows.

"AGLA"

Nortaricon for 'Ateh Gebir Leilam Adonai' – "Thou art mighty forever, O Lord."
See Agrippa, De Occulta Philosophia III.xi.

Cave: quia angelus tenebrarum se intrusit hic ut libri Quinti appendice apparabit.
Beware: For an angel of darkness intruded himself here as will appear in the appendix of the Fifth book.

(On the table)

	In fronte	
	On the forehead	
A sinistro		A dextro
On the left		on the right
	juxta pectus	
	next to the breast	

Directions regarding the table

These markings make most sense for someone resting or lying on the table. They would work well if one were to kneel before it and then fall forward (in fear, supplication, exhaustion, etc.)

Page 10

Gloria Patri et filio et Spiritui Sancto sicut, etc. Amen.

Glory be to the Father and to the son and to the Holy Ghost as, etc. Amen

1582 Martii 11 Sunday a Meridie hora 3a circiter

1582 March 11 Sunday from noon about the third hour

Translator's Note: i.e., about 3:00 PM

Page 11

Gloria, Laus, honor, virtus et Imperium Deo immortali invisibili, et Omnipotenti, in saecula saeculorum. Amen.

Glory, praise, honor, power and Dominion to immortal, invisible and Almighty God, forever and ever. Amen.

Page 12

Marti 11 14 Wensday mane circa horam 9a

March 14 Wednesday, in the morning about the 9th hour.

(in margin) Agrippa hath so, cap. 24, Lib. 3, Occultae Philosophiae

(in margin) Agrippa has so, in chapter 24, Book 3, of The Occult Philosophy

“Nariel”

Agrippa, in De Occ Phil III.24 gives a long compilation of things (mansions of the moon, signs of the zodiac, ages of the world, planets, etc) and the angels that preside over them. In particular, Noriel (qui ab aliis Uriel dicitur) super australem.

Noriel (by others called Uriel) over the south (i.e. wind and quarter.)

Fortitudo Dei, tecum semper est.

The strength of God is always with you.

(In margin) potius erat dicendum Michael: nam Gabriel est Praevalescentia Dei: et ita, fortitudo quidem, sed altioris gradus

Perhaps Michael should have been said: for Gabriel is the prevailing of God: and thus, the same strength, but of a higher grade.

Page 13

ANGELVS TVAE PROFESSIONIS.

The Angel of your profession.

Translator's Note: "Professio" is the technical term for a declaration of a vocation, e.g. a profession of faith, as when one takes holy orders. See note on "de Triplici hominis custode" below.

(In margin) vide Agrippam de Triplici hominis custode, Lib 3, cap 22

see Agrippa "On the Three-fold Guardian of Man", Book 3, Chapter 22

"de Triplici hominis custode"

This is the title of Agrippa, De Occulta Philosophia III.22, which begins

Triplex unicuique homini demon bonus est proprius custos: unus quidem sacer, alter geniturae, tertius professionis.

For every man there is a threefold good spirit as a proper keeper: one holy, another of the nativity, the third of profession.

The first spirit is similar to the concept of "guardian angel", the second spirit is like the Classical concept of "Genius" or a person's innate (and astrologically influenced) spirit or potential, and the third is the spirit of one's profession, path, etc. There is happiness when the second and third are in agreement, and unhappiness when they are not.

Book III, chapter 23 of Ficino's De Vita Libri Tres is about making Genius and Profession agree. Dee owned a copy of this work.

Laudate Dominum in operibus suis.

Praise the Lord in his works.

"Laudate..." – Sirach 39: 19 (Vulgate); Ecclesiasticus 39:14 (English)

Vulgate: florete flores quasi liliū date odorem et frondete in gratiam et conlaudate canticum et benedicite Dominum in operibus suis

KJV apocrypha: And give ye a sweet savour as frankincense, and flourish as a lily, send forth a smell, and sing a song of praise, bless the Lord in all his works

Geneva: And give ye a sweete smel as incense, and bring forth flowres as the lillie: give a smel, and sing a song of praise: blesse the Lorde in all his workes.

(In margin) vide Reuchlinum de Verbo Mirifico, de nomine NA

see Reuchlin "On the Marvellous Word", concerning the name NA

"NA"

Reuclin de verbo mirifico, II, sig e6v, (Stuttgart facsimile p 72)

Et sequitur: Nequaquam Jacob appellabit nomen tuum sed Israel: quoniam cum deo & homine praevaluisti: Ut est item vocabulum Na: quod in animi molestia

turbationibusque utimur. Sicut Moyses in numeris: Dimitte Na peccatum populi tui: quod vos interpretatum habetis: Dimitte obsecro. Et psalmo centesimo ac decimoseptimo: A na domine salvificia na. A na domine fortunifica na: quod vos elegantius sic: O domine salvum me fac: o domine bene prosperare.

And it follows: No more shall thy name be called Jacob, but Israel: for with god and man thou hast prevailed. And so it is with the name Na: which we use in trouble and disturbances of spirit. For instance Moses in Numbers: “Na, pardon the iniquity of thy people”, which you will have interpreted “Pardon, I beseech thee.” And also in Psalm CXVII “Ah Na, Lord, fortune-giving Na”, which you find more elegantly thus: “Save now, I beseech thee, O Lord: O Lord, I beseech thee, send now prosperity.”

The psalm is Vulgate 117:25, English 118:25.

‘A Na’ in the context of beseeching is reminiscent of the note on Anna and Annah in ‘John Dee His Note.’

Also, see Agrippa De Occulta Philosophia III.11

Et est nomen Dei Na nun-aleph, in perturbationibus et molestiis invocandum. – p 428, Brill edition

And the name of God Na is to be invocated in perturbationibus and troubles. –p. 474, Tyson edition.

(In margin) vide Reuclini librum de verbo mirifico de nomine PELE
see Reuchlin’s book On The Marvellous Word concerning the name PELE

“PELE”

Reuclin, De verbo mirifico II, sig e2r, (p 63 in the Stuttgart facsimile)

Quoque vos legitis in eo Iudicum loco: Nomen meum quod est mirabile. Sed tenet non eandem hic significationem quomodo in psalmo octavo: Domine dominus noster Quae admirabile est nomen tuum in universa terra: id est admiratione dignum & gloriosum: quod vocabulum Adir significat: hic vero peli: quod est miraculorum operator.

Also, you read in that place in Judges: My name which is wonderful. (But this does not have the same significance as in the eighth psalm: O Lord our Lord, how wonderful is your name in all the earth: that is, “worthy of admiration” and “glorious”: which the word Adir signifies.) here truly peli: which is “worker of miracles“

Agrippa , De Occulta Philosophia III.11

Origenes, splendidissimis quibusque philosophis non inferior, adserit contra Celsum in quibusdam divinis verbis mirandam latere virtutem; et in libro Iudicum ait Dominus: “Nomen meum quod est Pele (Peh Lamed Aleph), quod interpretatur apud nos ‘miraculorum operator’ sive ‘efficiens mirabilia.’

Origen, not inferior to the most brilliant philosophers, asserts against Celsus that wondrous virtue lied hidden in certain divine Words. And in the book of Judges the Lord says “My name which is Pele”, which signifies to us “a worker of miracles” or “bringing forth wonders.”

Page 14

(In margin) De sigillo Emeth vide Reuclini Artem Cabalisticam lib 3 et Agrippam lib 3

cap 11

On the seal of Emeth, Reuclin's "The Cabalistic Art", book 3, and Agrippa book 3, chapter 11

"Emeth"

The Seal of Emeth has a long history. The sources Dee cites are:

Agrippa De Occulta Philosophia III.11

nomen Emeth, quod interpretatur 'veritas' est, et est sigillum Dei.

the name Emeth, which is interpreted 'truth' and is the seal of God

Reuchlin, De Arte Cabalistica III, fol. LXIIr (p 284 in Bison Book edition)

Ehieh sigillat per Emeth, hoc est essentiam per veritatem. Sicut nobilis ille dictator ait Eliezar Haklir AMTh ChRTMD, Emeth est sigillum eius. Probat hoc ratio arithmetica quam imitantes si multiplicaverimus Ehieh per Ehieh surgent quadringenta quadraginta & unum, Quae simul sunt AMTh hoc est verum seu veritas, sicut Adonai Shalom – Domini Pax.

Ehieh seals through Emeth, that is though essential truth. As that excellent teacher Eliezar Haklir says "Emeth is his seal." Arithmetic reasoning proves this; for if we in such a way multiply Ehieh by Ehieh, four hundred forty one will arise, which is at once Emeth, that is 'true' or 'truth' and Adonai Shalom "Peace of the Lord."

ibid, fol. LXVIr (p 300 in Bison edition)

Ubi post Tetragrammaton repitur YHV quod est symbolum ipsius Ehieh, hoc est entis per aequalitate numeri....Est enim sigillum Dei YHV quo Ehieh sigillavit mundum, et dicitur AMTh, id est verum, quippe quod in se ipsum arithmetice multiplicando nascitur.

And after the Tetragrammaton is found YHV which is a symbol of that Ehieh, which is "Being", by equality of number....And YHV is a Seal of God, by which Ehieh has sealed the world., and it is called Emeth, that is "truth", since it is born by multiplying it arithmetically by itself.

SIGILLUM DEI

The Seal of God

Valete

Farewell

Soli Deo omnis honor Laus et Gloria Amen.

To God alone, all honor praise and glory. Amen.

"Soli Deo..." I Timothy 1:17

Vulgate -- regi autem saeculorum immortalis invisibili soli Deo honor et gloria in saecula saeculorum amen

KJV--Now unto the King eternal, immortal, invisible, the only wise God, *be* honour and glory for ever and ever. Amen.

Geneva – Now unto the King everlasting, immortal, invisible, unto God onely wise, be honour and glorie for ever and ever, Amen.

Page 15

Martii 15. Thursday. Hora 1 1/4 a meridie
March 15. Thursday. From midday 1 1/4 hours.
Translator's Note: 1:15 PM

Invoke nomen Domini, et agnoscetis eum.
Invoke the name of the Lord, and you will know him.

“Invoke....agnoscetis”

Invoco/agnosco is a nice pair of synonyms for *obsecro/confiteor*, the words used for the etymology of Annael in “John Dee His Note” above.

Deus misereatur nostri, et benedicat nobis&c.
May God be merciful unto us and bless us, etc.

“Deus misereatur...” -- Psalm 66:1 (Vulgate); Psalm 67:1 (English)

Vulgate ex Septuaginta: Deus misereatur nostri et benedicat nobis illum vultum suum super nos et misereatur nostri DIAPSALMA

Vulgate ex Hebraeo: Deus misereatur nostri et benedicat nobis illustret faciem suam super nos SEMPER

BCP: God be merciful unto us, and blesse us: and shew us the light of his countenance, and be mercifull unto us.

KJV: God be merciful unto us, and bless us; and cause his face to shine upon us; Selah.”

Geneva Bible: God be merciful unto us, and blesse us, and cause his face to shine among us. Selah.

(In margin) Of Salamian you may read in the call Diei Dominicae in Elementis Magicis Petri de Abano.

Of Salamian you may read in the call of Sunday in “Magical Elements” of Peter of Abano

“Salamian”

De Elementis Magicis (attributed to Peter of Abano) is part of De Occulta Philosophia Liber Quartus.

per nomina sanctorum Angelorum, qui dominantur in quarto exercitu, et serviunt coram potentissimo Salamia, Angelo magno et honorato: et per nomen stellæ, quæ est Sol, et per signum, & per immensum nomen Dei vivi, et per nomina omnia prædicta, conjuro te Michael angele magne, qui es præpositus Diei Dominicæ: et per nomen Adona, Dei Israel, qui creavit mundum et quicquid in eo est, quod pro me labores, et admoleas omnem meam petitionem, juxta meum velle & votum meum, in negotio et causa mea.

By the names of the holy Angels, who rule in the fourth company, and serve before the face of the most powerful Salamia, a great and honored Angel, and by the name of the star, which is Sun, and by the sign and unfathomable name of the living God, and by all the aforesaid names, I summon thee, great angel Michael, who art placed over the Lord's Day, and by the name Adonai, the God of Israel, who created the world and whatsoever is in it, that thou labor for me, and undertake all my petitions, according to my will and my desire, in my business and cause.

“admoleas” – Translator's Note:

This word is not to be found in any of the dictionaries cited in the bibliography. Here, it

is taken as *admolior*, turned non-deponent, and made 3rd instead of 4th conjugation. This is a not unreasonable medievalism. It is also a plausible scribal or transcription error (medieval or later.)

Page 16

(In margin) De OCH vide in libello Arbatel in (sol sign)

About OCH, see Arbatel's little book, under Sun.

“OCH”

In Arbatel de Magia Veterum (printed as part of De Occulta Philosophia Liber Quartus) Och is the spirit of the Sun. Raphael confirms this two lines later when he says OCH is “mighty in the sonne beames.” OCH is also associated with gold and wealth.

I am Fortitudo Dei

I am the Strength of God.

Fortitudo Dei

This is what Dee calls Michael in ‘John Dee His Note’; this, combined with all of the solar references immediately preceding (see the note on OCH), makes Dee's conclusion that this angel is Gabriel pretty inexplicable. The angel neither confirms nor denies Dee's assertion about the visitor's identity.

See page 16 for another example of potential Michael/Gabriel confusion.

“What thow hast written, that hast thow written”

cf Pilate's words “What I have written, I have written.” (John 19:22, Geneva Bible and KJV.)

“POLIPOS”

Mi: Dost thow understand it?

Dee: No, God knoweth.

In De Occulta Philosophia, III.34, Agrippa gives the Hebrew names of the twelve apostles, including quartus PEH-VAU-LAMED-YOD-PEH-VAU-SHIN Polipos, quem nuncupamus Philippum.

The fourth Polipos, whom we call Philip.

Dee may be missing the significance of the name, not the immediate reference, but it seems out of character for him not to have added a marginal note in such a case.

(In margin) It is in Elementis Magicis Petri de Abano, printed with Clavis Agrippae

It is in Peter of Abano's “Magical Elements”, printed with the “Key” of Agrippa.

Page 17

“I lived with Esdras”

Uriel appears in books 4-13 of II Esdras in the Apocrypha, where he leads Esdras through dreams about the mystery of human destiny and visions of the Last Days.

“I lived with Tobie: Tobie the younger”

Tobias' adventures with Raphael are found in Chapters 4-12 of the apocryphal Book of Tobit.

*Mysteriorum Liber
secundus*

[The top quarter of a page is missing]

...] mysteryes, [...

...] ow toward a thing, r [...

...] howse is hollow, it is empty and voyde [...

...] ants: The God of heven and erth, will send into [...

NOTE. We bring tydings *of light. The Lord is owr [...
you and we prayse to gither. His name be prayed for ever O [...
in his Mysteries: O holy and eternall God.

Δ he bowed down to the Chayre and then to the table, and sayd, *Benedictus qui venit in*, (and there stayed a little) and sayd agayn, *Benedictus qui venit in, nomine Domini*.

Δ Than cam in Michaël, with a sword in his hand, as he was wont: and I sayd unto him, are you Michael?

Michael
Fortitudo
Dei.

Mich. Dowl not: I am he which rejoyceth in him that rejoyceth in the Fortitude and strength of God.

Δ Is this Forme, for the Great Seale, perfect?

Mi. The forme is true and perfect.

My Oathe
or vow
required
for secrecie

Thow shalt sweare by the Living God, the strength of his Mercy, and his Medicinall vertue, powred into mans sowle never to disclose these Mysteries.

Δ yf No man, by no means, shall perceyve any thing herof, by me, I wold think that I shold not do well.

Mi. Nothing is cut from the Churche of God. We in his Saincts are blessed for ever.

We separate the, from fyled and wycked persons: We move the to God.

Δ I vow, as you require: God be my help, and Gwyde, now and ever, *amen*.

MIC. This is a Mystery, skarse worthy for us ourselves, to know, muche lesse to Reveale. Art thow, then, so Contented?

Δ I am: God be my strength.

Mic. Blessed art thow among the Saincts: And blessed are you both.

Δ
To E.T.
he spake.

I will pluck the, from among the wycked [he spake ^Δ to my skryer.]

Thow Commyttest Idolatry.

But take hede of Temptation:

The Lord hath blessed the. This is a Mystery.

Dee

Dee, what woldest thow have?

Δ *Recte sapere et Intelligere &c.*

Mic. Thy Desyre is graunted the.

Use [...

[The top quarter of a page is missing]

...] with [...
...] they are corrupted [...
...] They have byn used to the wycked Ther [...

...] I will shew the in the mighty hand and strength of God, what his Mysteries are: The true Circle of his æternitie Comprehending all vertue: The whole and sacred Trinitie. Oh, holy be he: Oh, holy be he: Oh, holy be he. Uriel answered, *Amen*.

The Circle of Æternitie...

Mic. Now what wilt thou? Δ I wold full fayne procede according to the matter in hand.

40 Mi. Divide this owtward circle into **40** æquall partes: whose greatest numbers are fowre. See thou do it presently.

Δ I did so. Dividing it first into fowre: and then every of them into ten. He called Semiel, and one cam in and kneled down: and great fyre cam out of his mowth. Michael sayde, To him, are the Mysteries of these Tables known. Michael sayde, Semiel (agayn) and by and by, he said, O God thou hast sayd and thou Livest for ever. Do not think here I spoake to him. Δ he spake that to us, least we might dowte of his last speches, as being spoken to Semiel: which he directed to the æternall god and not to Semiel. Semiel stode up, and flaming fire cam out of his mowth: and than he sayd, as followeth:

Δ Semiel, this etymologie is as though he wer the secretarie, for the Name of God.

The Tables

Sem. Mighty Lord, what woldest thou with the Tables?

Mi. It is the will of God, Thou fatche them hither.

Semiæl

Sem. I, am his Tables. Behold these are his Tables: Lo where they are.

40 White Creatures

Δ There cam in **40** white Creatures, all in white Sylk long robes: and they like chyldern: and all they fallyng on theyr knees sayd, Thou onely art Holy among the highest. O God, Thy Name, be blessed for ever.

Δ Michael stode up out of his chayre, and by and by, all his legs semed to be like two great pillers of brass: and he as high as half way to the heven. And by and by, his sworde was all on fyre and he stroke, or drew his sworde over all theyr **40** heds. The Erth quaked: and the **40** fell down: and Michael called Semiæl, with a thundring voyce, and sayd, Declare the Mysteries of the Living God, our God, of one that liveth for ever.

Sem. I am redy. Δ Michael stroke over them, with

Δ Semiel - forte significat Nomen meum Deus. Ita quod Tabulae istae sunt Nomen Dei, vel Nomina Divina.

his sword agayne: and they all fell down, and Uriel allso unto his knees. And commonly at the striking with his sword, flamyng fyre like lightening did flash with all.

Mi. NOTE: here is a Mysterie.

Δ Then stept furth, one of the **40**, from the rest, and opened his brest, which was covered with Sylk, and there appeared a great **T** all of Gold.

The very fashion of the T was thus: 

Mi. Note the Number. Δ over the **T**, stode the figure of **4**, after this manner: 

The **40**, all, cryed, yt liveth and Multiplied for ever: blessed be his name.

Δ T, in the holy language is Giscg vide lib. 5. post et est ultima Alphabeti litera.

Δ That creature did shut up his bosome, and vanished away, like unto a fyre.

Mi. Place that, in the first place. It is the name of the Lorde.

Δ Than there seamed a great clap of thunder to be.

Then stepped (before the rest) one other of the **40**, and kneled as the other did before. And a voyce was herd saying, Prayse God, for his name is reverent. Michael sayd to me, say after me thus,

Deus Deus Deus noster, benedictus es nunc et semper: amen.

Deus Deus Deus noster, benedictus es nunc et semper: Amen.

Deus Deus Deus noster, benedictus es nunc et semper: amen

Δ Then this Creature opened his breast, and fyre cam oute of the stone as before and a great romayne **G** appeared.

G: dicitur Ged lib. 5.

Mi. Write with reverence, These Mysteries are Wunderfull, the Number of his name, and knowledge.

Lo, this it is, **.9**. Behold, it is but one, and it is Marveyulous.

Δ Then this Creature vanished away.

Mi. The Seale of Gods Mercy: blessed be thy name.

Δ It semed to rayne, as thowgh it had rayned fyre from heven. Then one other of the **40** was browght furth: The rest all fell down and sayd, **LO**, thus is God known.

N, dicitur, Drux.

Then he opened his brest, and there appered an **n**, (not of so big proportion as the other), with the number of **7** over it.

Mi. *Multiplicatum est Nomen tuum in terra.*

Δ Then that man vanished away as it were in a golden smoke.

Mi. Thow must not write these things, but with great devotion.

He Liveth. Δ Then cam an other fowrth. Then all falling down sayde, *Vidimus Gloriam tuam Domine.* They were prostrate on theyr faces. Then this Creature opened his breast and he had there a Tablet all of Gold (as it were) and there appered a small **t** uppon it: and the figure of **9** under this Letter **t**.

Δ Giscg.

Mi. Mark it, for this is a Mysterie. Δ Then that shewer (of the **40**) seamed to fly up into the ayre, like as it were a white garment.

Mi. *Illius Gloria sit nobiscum.* Δ All sayd, *amen*: and fell down.

Δ Na.

Δ Then stode up an other, and opened his bosom, and shewed on his brest bare (being like sylver) a small **h**; and he pointed to it, and over it was the number of **22**.

Angeli Lucis

Mi. *Et est numerus virtutis benedictus.* Δ This Shewer went away like a White Cok flying up. *Videte Angelos Lucis.*

Δ There cam an other in, and sayd,

Et sum Finis et non est mihi Numerus. Sum Numerus in Numero.

Et omnis Numerus est mihi Numerus. Videte.

Δ Drux.

Δ There appeared a small **n** on his skyn, being all spotted with Gold.

Then he went away like three fyres, red flaming, and coming to gather in the myddst of the firmament. Δ You must Note that in the stone the whole world in manner did seme to appere, heven, and erth, &c.

Mi. (Δ he cryed with a lowde voyce) *Et est vita in cælis.*

Δ Then stepped furth one and sayd, *Et ego vivo cum bene viventibus*, and withall he kneeled down: and Michael stepped furth and toke of his veale on his brest and he made Cursy and stode up.

Mi. *Vivamus Halleluyah. O Sanctum Nomen.*

Δ All fell down on theyr faces, and Michael stroke over them with his sword and a great flash of fyre: And this man his brest seemed open that his hart appeared bleading, and therein the letter m, and **6**, over it thus **6**

Δ
Tal

Mic. *Benedictus est Numerus Agni.* **m**

Δ Hereuppon They all fell down.

Mi. *Orate invicem.* Δ Hereuppon we prayed a psalmé; ^{my skryer} saying one verse, and I the other &c.

Δ
Med

Mi. *Omnia data sunt a Deo.* Δ – Then cam one in, having a rownd Tablet in his forhed and a little o in his forhed: and **22** over it.

Mi. *Et non est finis in illo.*

Benedictus es tu Deus. Δ and then that shewer vanished away: He flew up, like a rownd raynbow knyt together at the endes.

Mi. *Angeli a nomine tuo procident Domine.*

Tu es primus O Halleluyah.



Δ One stode up and the rest fell down, and out of his mowth that stode, cam a sworde: and the point, a Triangle, and in the myddest of it a small **a** thus , of pure gold, graven very depe:

Et Numerus tuus vivit in cæleris, sayd this shewer. The number was ²⁰**22** over the **a**.

This shewer went away with great lightening covering all the world.

Δ
Vn
Corrected thus,
after, by
Uriel
to be **20**

Mi. *Nomen illius est nobiscum.* Δ He stroke agayne with his

Δ
Drux

sword over them. Then stode one up: who, upon his garment had an n: and he turned about: and on his back were very many (ens) **n**.

Mi. *Creasti tu Domine Angelos tuos ad Gloriam tuam.* Δ Over the **n**, was the number of **14**, over that **n** (I meane) which was onely on his brest.

Mi. *Et te primus Creavit Deus.* Δ Then the shewer flew up like a star.

Δ
Vn

And an other cam in, all his cloth being plucked up: and so seamed naked: He hath a little **a**. This **a**, did go rownd about him: begynning at his feete: and so spirally upward: and he seemed to be all clay. Over the **a**, was the number **6**.

Mi. *Et creata sunt et pereunt in Nomine tuo.* Δ and therwith

Note these 3
parts

this shewer fell down all into dust on the Earth: and his white garment flew up, like a white smoke: and allso a white thing did fly out of his body.

Surgit Innocentia ad faciem Dei.

Δ Michael did over them agayn with his sworde, and it seemed to lighten. He began to speak, and he stopped suddenly, and the fyre flew from his mowth.

Mi. *Innocentium Nomina, et sanguinem vidisti Domine a Terra, et Justus es in operibus tuis.* Δ Then cam one in, with a garment

Δ
Na

all bluddy. he was like a chylde, he had a ball in his hand of perfume which smoked: and he hath upon his forhed a little **h**. He bowed to Michael: and Michael sayd, *Numerus tuus est infinitus, et erit finis rerum.* Δ This shewer seemed to powre him self away

like a flud of blud: and his garment flew upward.

Mi. *Non est illi numerus.*

Omnia pereunt a facie Dei, et a facie Terræ.

†
Med

Δ Then stepped one furth, and like a water running rownd about him, and he cryeth miserably, O benedictum Nomen tuum Domine.

Numerus periit cum illis. Δ A little ,o, with **18** over it, appered.

Δ This shewer seemed to vanish away, and to cause a great water remayn over all.

Mi. *Lux manet in tenebris. Gloriosum est Nomen tuum.*

Δ Then stept one furth from the rest, who fell down, as theyr manner was.

Δ Note: All the Cumpanies of these **40**, stode five to gither, and five to gither, and so in eight Cumpanyes; each, of five.

Δ This was a very white one: The upper partes of his throate, seemed open and there seemed to cum out of it fyre, in very many and diverse cullours. he sayd, *Trinus sum.*

Mi. *Benedictum sit nomen El.*

Δ
Ur

Δ Than in the myddle of the fyres or smoke semed an ,1, thrise placed, on a bluddy cross, and over the ,1, the number **26**.

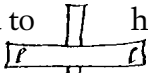
Δ This shewer seemed to  have three mens heds and to vanish away in a myst with a thunder.

Mi. *Labia mea laudant Dominum.*

Δ Then cam a very fayre  yong one in with long heare hanging on her (or his) sholders: and on her belly appeared a great scotcheon; to hir, or him, Michael gave a flame of fyre: and she, or he, did eat it.

Mi. *Et hic est El:* and so appeared a little ,1, on the scotcheon, and it waxed bigger and bigger: and a fyre did seeme to go rownd about it.

Mi. *Benedicta sit ætas tua:* Δ And there appeared ,**30**, under the **1**.

Δ There cam a great many of little fyers and did seeme to elevate this yong woman (or child) out of sight.

Michael stroke his sword over them agayn, and sayd,

Natus est illa Lux.

Ille est Lux noster.

Δ Then stept out an other and opened his white silk garment uppermost: and under it, he seemed to be sowed up in a white silk cloth.

Δ
DruX

He had in his forhed an ,n, in his brest an ,n, and in his right hand an ,n.

Mi. *Numerus tuus est benedictus.* Δ They all fell down, saying, *Numerus tuus est Nobiscum: Nec adhuc novimus finem illius Venies cum numero tuo O unus in æternum.*

Δ and they fell all down agayn. This shewer departed clyming up into the ayre, as if he had clymed on a ladder.

Mi. *Linguis suis cognoverunt eum.*

Δ All sayd, *Benedictus est qui sic et sic est*, throwing up into the ayre threcornerd trenchers of this fashion  all of Gold. The one side of the trenchers was thus marked, and the other side had nothing on.

Δ Then stept one oute: and fyre cam out and in of his mowth: he kneeled, the rest fell down. This seemed a transparent body, and he had in his eyes a small 1: and in his forhed the figure of **8**.

Ur

Mi. Note this, under. I meane the figure **8**. Thus, .

Δ All sayd, *Et es verus in operibus tuis*: and so he vanished away in a flame of fyre.

Δ
Ged - G

Mi. *Gaudete omnes populi eius, gaudete omnes populi eius, ab hinc Gaudete.* Δ — All sayd, *Amen*.

Δ . Note
this to be
the first
that vanished
away, going
behynde
Michael.

Δ one stept furth saying, *Incipit virtus nostra*, he being covered under his robe, all with armor: and hath a great **G** on his armor. and the figure of ,7, over it. He went behynde Michael and so vanished away.

Mi. *Recte vivite omnes Sancti eius.*

Δ
Don

Δ One stept furth: and opening his brest, there appered a boke, and turning over the leaves there appeared nothing but a little **r**, and **13** over it. He went behinde the Chayre and so vanished away.

Mi. *Hic est Angelus Ecclesiæ meæ, qui doceat Ille viam meam.*

Δ
Na

Δ There stept oute a playn man, and under his garment a gyrdel, and under his gyrdle a Rod: and in his hand he had a sworde, and in his mowth a flame of fyre: he had a great **H** uppon his sworde and under it **22**. He went behynde the Chayre *etc.*

Michael standing up still uppon his leggs, like pillers of brass.



Δ I axed yf I shold not cease now, by reason of the folk taryng for us to come to supper.

Mic. Lay away the world. Contynue your work:

Coniunxit spiritum mentibus illorum.

Δ
Med
ged

Δ Then stept out one, having under his garment a little Chest, and therein a mans hart raw: and the hart was thus with two letters, one on the one side ,**o**, and on the other a ,**g**: [Δ — As in scotcheons of armes, where the man and his wives armes ar joyned *per pale*, as the heralds term it.]



This shewer shut up the chest

and went his way.

Mi. *Numerus illius est sine numero.*

Δ Then cam in an other, saying,

Tempus est. Deus vestrum agnoscite.

Δ
Gisg

Δ This shewer his armes reached down to his feete: he shewed furth his right hand and in it a little ,**t**, and **11** under it.

Δ
Gon con puncto,
y.

Mi. stay; place this, in the second place. This went away.

Δ . *Imago*: I writ first: but, aunciently, and vulgarly both in writing and print, you shall finde *ymago*, though not according to the Latine tung

Mi. *Ymago tua, (mors,) est amara.*

Δ Then cam one in, with a big belly, and fat cheekes: an half sword perced his hart, and a little ,**y**, written on it.

Justus est malis deus noster. Δ The number of **15** under it.

Mi. Place it in the former place.

Δ
Med

Mi. *Opera fidelium, Delectatio mea.* [Δ Then cam one in.]

Hic est Deus noster. He shewed the letter of **o** on his naked brest, and the figure of **8** under it. He went away.

Δ
Graph

Mi. *Ecce, Iniquitas regnat in domo mea.*

Δ Then stept one oute very lean, all his body full of little **e**, and under every one of them, **21**. He went away behynde the chayre.

Δ
Pa - b

Mi. *Bestia devoravit populum meum, peribit autem in æternum.*

Δ Then stept out one in bluddy apparell, all his body full of serpents heds and a **b** on his forhed, and the number of **10** over it . He went away.

Mi. *Iniquitas Abundat in templo meo, et sancti vivunt cum Iniquis.*

Δ — One very lean, hunger sterved cam out, an **A** on his brest, and ,**11**, over it,

Δ I think
it be
superfuous } +

and so went away.

Δ There cam in an other.

Mi. *Iniqua est Terra malitiis suis.*

Δ Then cam in one who drew out a bluddy sworde, on his brest a great romayn I, and **15** over it. he went his way.

Mi. *Angeli eius ministraverunt sanctis.* Δ Then stept one oute with a Target and a little a on it, and over it the number of **8**. He went away.

Mi. *Regnabit Iniquitas pro tempore.* Δ They all cryed Halleluyah.

Δ
Uriel
corrected
it after,
to be under

Δ Then stept one furth with a golden crown, and a great arming sworde: his clothing all of gold, with a letter r on his sword and **16** over it, and so he went away.

Mi. *Nulla regnat virtus super terram.* Δ Then stept one oute, having all his body under his white sylken habit (as they all, had) very brave after the fashion of those dayes, with great ruffs, cut hose, a great bellyed dubblet, a velvet hat on his hed, with a feather: and he advanced him self braggingly: He had burnt into his forhed a little n: and Michael sayd, *Non est numerus illius in Cælis.* Δ He went away.

Mi. *Antiquus serpens extulit caput suum devorans Innocentes. Halleluyah.*

Δ Then cam one who put of his white habit: and he toke a sword, and smote up into the ayre, and it thundred: and he had a seal (suddenly there) very gorgeous of gold and precious stones. he sayd,

Regnum meum: Quis Contradicet!

Δ He hath proceding out of his mowth, many little (enns) n, and on his forhed, a great **A**.

Mi. *Non quòd est A, sed quòd contradicit A.
Nec portio, nec numerus eius invenitur in cælo.
Habet autem Numerum terrestrem*

Mysterium

*Mysterium
nobis reve=
landum*

Δ He shewed three figures of ,**6**, set in triangle thus, **6⁶6**

Mi. *Vobis est Mysterium hoc, posterius revelandum.*

Δ And there cam a fyre and consumed him, and his chayre away, suddenly.

Δ My skry=
er had omit=
ted to tell
me this, or
els, it was
not told
and shewed,
but Uri=
el did after
supply it
by the
skryer
The first
letter of
Perturba=
tur, doth
not make
shew, of
the letter
following
as other
before
did.

Mi. *Perturbatur terra iniquitate sua.*

This shewer, his garments, white, under: his face as brass: his body gre=
vous with leprosy: having uppon his brest an **O**, with the number of
.10. under it: and so he departed.

Mi. *Surgite O Ministri Dei. Surgite (inquam) Pugnate: No=
men Dei est æternum.*

Δ Then cam two oute to gither: they had two edged swordes in theyr hands, and fyre cam oute of theyr mowthes. One had a **G**, and 5 over it, the other had...

[Δ – We fell to prayer, whereuppon Michael blessed us.]

The other had an h on his sword, and **14** under it: and so they went away.

Mi. *Omnis terra tremet ad vocem tubæ illius.*

Δ One stept out, and under his habit had a trumpet. he put it to his mowth, and blew it not. On his forhed a little ,o, and **17** under it. He went away.

Mi. *Serva Deus populum tuum, Serva Deus populum tuum Israel, Ser=
va (inquam) Deus populum tuum Israel.* Δ He cryed this, allowde.

Δ
Fam

Δ One appeared with a fyry sword, all bluddy, his vesture all bluddy his vesture all bluddy, and he had s.

Est numerus in numero. Δ He went away.

Δ I understand it to be a letter, and the number **5** also. Mi. So it is.

Δ
Uriel also
did correct
this place
with delive
ring this
in the
place of
the other des
cription
before.

Δ There cam one in with diverse owgly faces, and all his body skabbed.
Mi. *Nunc sunt Dies tribulationis:* Δ He had an a on his
forhed and the Number 5 under it.
Mi. *hic est Numerus predictus.*

Mi. *Audite, consummatum est.* Δ This had a great pot of water
in his hand and uppon the pot, graven, a with 5 under it. He
departed in fyre.

Mi. *Angele preparato Tubam tuam.*

Δ Then cam one oute with a Trumpet. *Venit Tempus.*

Δ He offered to blow, but blew it not. on the end of his Trumpet
was a little a and 24 under it. he went away.

Δ They all now seemed to be gon: Michael and all.
He cam in agayn and two with him. And he sayd, *Hii duo*
Cælati sunt adhuc. They two went away.

Mi. *Vale. Natura habet terminum suum.*

Δ He blessed us and florished his sword towards, and over us,
and so went away and Uriel after him: who all this while
appeared not.

Δ After supper Mr. Talbot went up to his chamber to prayers: and
Uriel shewed himself unto him: and told him that somewhat
was amyss, in the Table or seale which I had
byn occupied about this day. And thereuppon, Mr. Talbot cam
to me into my study: and requyred the seale (or Tables) of
me: for he was wished to correct something therin, (sayd he)
I delivered him the seal, and he brougth it agayn within
a little tyme after, corrected: both in the numbers, for quantity
and some for place over or under: and allso in one letter or
place omitted. Which I denied, of any place omitted by me,
that was expressed unto me. And the rather I dowted, uppon
Michael his words last spoken, uppon two places then remay=
ning yet empty: saying, *Hii duo Cælati sunt adhuc.* But
If I had omitted any, there shold more than two have wanted.
Whereuppon we thought good to ax Judgment and dissolving
of this dowte, by Michael. And comming to the Stone
He was redy: I prepounded this former Dowte. He answered,

Mi. *Veritas est sola in DEO. Et hæc omnia vera sunt.*

The
Descryer, or
The Skryer
omitted to
tell.

you omitted no letter or history that was told you. But the
skryer omitted to declare unto you. Δ May I thus recorde it?
Yt is justly reformed by Uriel: the one being omitted of the descrier
and the other not yet by us declared, might make that phrase
meete to be spoken, *Hii duo cælati sunt adhuc.*

Mi. Thow hast sayd. Δ I pray you to make-up that one
place yet wanting. Then he stode up on his great brasen leggs
agayn: He called agayn, Semiael Semiael. Then he cam,
and kneled down.

Consummatum est. Δ The shewer (a white man) pluckt

oute a trumpet, and put it to his mowth, as though he wold blow, but blew not: and there appeared at the ende of the Trumpet the greke ω. There arose a myst, and an horrible Thunder.

Mi. It is done. Δ Then of the three ⁶6 before Noted, with his finger he put oute the two lowermost: and sayd, *Iste est numerus suus*. And Michael did put his finger into the trumpets ende, and pulled furth a rownd plate of Gold, wheron was the figure of .1. with many circles about it, and sayd *Omnia unum est*.

Semi Eil

Δ The forme of the world which appered before, vanished away: and Se myeil went away. And Michael cam and sat in his chayr agayn:

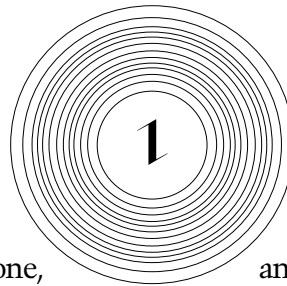

and his brasen leggs wer gone, and uppon our pawsing he sayd, Mi. Go forward. Do you know what you have already written? *Laudate Dominum in Sanctus eius*.

Note: The Circumference (which is done) conteyneth 7 names: 7 names, conteyn 7 Angels: Every letter, conteyneth 7 Angels: The numbers are applied to the letters.

Whan thow dost know the 7 names, thou shalt understand the 7 Angells.

The declaration of the Numbers

The Number of 4, pertayning to the first **T**, is a Number significative: signifying, to what place thow shalt next apply the eye: and being placed above, it sheweth removing toward the right hand: Taking the figure for the number of the place applyable to the next letter to be taken. The under number, is significative: declaring, to what place thow shalt apply the next letter in the Circumference, toward the left hand. Which thow must reade, untill it light uppon a letter, without number, not signifying. This is the Whole. So shalt thow fynde the 7 principall Names: known with us, and apply= able to thy practise.

Make experience.

Δ Then telling from ⁴**T**, 4 more places (toward the right hand) exclusively, I finde in that fowrth place, from **T**, (but being the fifth from the beginning, and with the begynning) this letter **h**: with **22**, over it. Therefore, I procede to the right hand, 22 places: and there I finde **A**, and **11** over it. Going then toward the right hand 11 places furder: I finde a little **a** with **5** under it: by reason of which under place of 5, I go toward the left hand, 5 places, exclusively; where I finde **o** with **10**, under it: wheruppon I procede to the left hand, farder by 10 places, and there I see the letter **t**, and **11**, under it: and therefore going to the left hand 11 places, I see there the letter **h** alone without any number. Wherefore, that letter, endeth my word, and it is in all, **ThAaoth**: Ys this, as it shold be?

Mi. That is not the name. Thow shalt understand all in the next Call. The Rule is perfect. Call agayn within an howre

Calls

Δ Note these doings to be accounted Calls

and it shalbe shewed.

Δ The howre being come we attended Michael his return to make the Practise evydent of his first Rule.

Mi. *Salvete.*
Thow diddest erre: and herein hast thow erred: and yet notwithstanding no error in the, bycause thow knowest not the error.

Understand that the 7 Names must comprehend, as many letters in the whole, as there are places in the circle: Some letters are significative of them selves. In dede no letters, but dubble numbers, being the Name of God. Thow hast erred in the first name, in setting downe **Aa**; that is, twice a together, which differ the word. Which thow shalt Note to the ende of thy work: Where soever thow shalt finde two a a together the first is not to be placed within the Name, but rather left with his inward power. Thow shalt fynde 7 Names proceeding from three generall partes of the Circumference: My meaning is, from three generall letters: and onely but one letter, that is, this letter **A.** Accownt thow, and thow shalt finde the names just. I speak not of any that come in the begynning of the word but such as light in the myddest: Prove; Prove: and thow shalt see. Whereas thow hast **go**, it is to be red **og**. This is the whole.

Dubble Numbers



Note

Δ Note: 7 names, proceeding from 3 generall places of the Circumference or 3 generall letters, being but one letter and that, Δ.

Δ — I have red in Cabala of the Name of God of 42 letters: but not yet of any, of 40 letters: That of 42 letters is this,

אב אלהים בן אלהים רוח הקדש אלהים
שלשה באחד אחד בשלשה

id est: Pater Deus, Filius Deus, spiritus sanctus Deus: Tres in uno, et unus in tribus. Vel Trinitas in unitate et unitas in Trinitate.

Δ vide Galatinum, lib. 3. cap. 11

Or thus, אב אל בן אל רוח הקדש אל אכל לא שלשה
אלהים כי אם אלוה אחד

which in Latin is, *Pater Deus, Filius Deus, et Spiritus Sanctus, Deus, attamen non tres dii sed unus Deus.*

And as this is of God, Unitie in Trinitie, so of Christ onely (the second person of the Divine Trinitie) the cabalists have a name explained of 42 letters, on this manner,

נאשר הכפש המשכלת והבשר אדם אחד
בן האל והאדם משיח אחד

That is in Latine, *Sicut anima rationalis, et caro, homo unus, ita Deus et homo, Messias unus.*

I am not good in the hebrue tung, but, you know my meaning.

Mi — The letters being so taken oute, being a name, and a number, doth certefye the old rule of 42 letters, whan you restore them in agayn.

Δ 42, are here in potentia, but, non Actu

The Vertu of this Circle



Mi — Note, Oute of this Circle shall no creature pass, that entreth, yf it be made uppon the earth. My meaning is, if he be defyled: This shalt thow prove to be a mysterie unknown to man.

ADAMS
TREA=
TISE,
Δ He mea
neth my
Booke that
I call
Soyga

Beasts, birds, fowle and fish do all reverence to it: In this they were all created. In this, is all things conteyned. In tyme thow shalt finde it, in ADAMS Treatise from Paradise. Looke to the Mysteries: for they are true.

A and ω: Primus et Novissimus; unus solus Deus vivit nunc et semper: Hic est, et hic erit: Et hic, sunt Nomina sua Divina.

Dixi:

Thow art watcht all this night: who is even now at the Dore:
Clerkson.

Blessed are those, whose portion is not with the wicked.

Benedicamus Dominum. Halleluyah.



Tuesday the 20 of Marche: *circa 10^a mane.* / /ers to them.

Δ Are you Uriel?
Ur. I am. We thank the for thy great good will. / / and corrected certayn pray=
We cannot viset the now. At the twelfth howre thow shalt use us. Δ. I had made, and written, ^

Δ *Fiat voluntas Dei.*

A meridie circa 2a

Δ At the twelfth howre, my partner was busyed in other affayres, and so contynued tyll about 2 of the Clok: when; we comming to the stone, fownd there Michael and Uriel: but Michael straight way rose up and went out, and cam in agayn, and one after him, carrying on his right shulder, 7 little baskets, of gold they seamed to be.

Baskets

Shut }
Dores }

Mi. Shut up your doores. Δ I had left the uttermore dore of my study, open: and did but shitt the portall dore of it.

Δ He toke the 7 Baskets, and hanged them rownd about the border of a Canapie, of beaten gold, as it were.

Mi. *Ecce, Mysterium est. Benedictus Dominus Deus Israel.*

Δ Therewith he did spred oute, or stretch the Canapy : Whereby it seamed to cover all the World [which seamed to be in the stone allso, heven, an erth] so that the skryer could not now see the heven. And the baskets, by equall distances, did seeme to hang in the border of the horizon

Mi. What wold you have Δ *Sapientiam*

Mi. Rede the names thow hast written. Δ I had written these according to the Rule before given, as I understode it.

Th ~~h~~ aoth

Gal ~~h~~ as

Gethog

Horlōn

Innon

A^aoth

Galets.og

Mi. Loke to the last name. Δ I had written (as appeareth) **Galetsog**

by misrecke[n]g the numbers. Where I fownd it shold be **Galethog** with an **h** and not s.

Mi. Lo, els thow hadst erred. They are all right, but not in order
The second is the first (his name be honored for ever) The first here, must be our third and the third here, must be our second : thus set downe.

- .1. Galas.
- .2. Gethog.
- .3. Thaoth.
- .4. Horlon.
- .5. Innon.
- .6. Aaoth.
- .7. Galethog.

Mi. Work from the right, toward the left, in the first angle next unto the circumference

Δ He shewed than, thus, this letter 

M. Make the number of 5 on the right hand, (that is, before it) at a reasonable distance, thus  5

Δ After that, he shewed the second letter, a great roman A, thus,  24

Then he shewed  30

Then —  21

Then —  9

Then he shewed  14

Then he shewed this compownd letter, with the circle and cross 

He willed me, at each corner of these segments of circles, to make little Crosses and so I did.

Δ After every of the 7 letters shewed he did put them up in his bosom assone as he had shewed them fully. The plates wheron those letters were shewed, hath the forme of the segment of a circle, thus  : and seemed to be of pure gold. When the 7 letters were placed, he sayd

Omnia unum est.

Then he pulled all the 7 plates out of his bosom and Uriel kneeled down before him. Then the plates did seeme to have two wings (eche of them) and to fly up to heven under the Canapye.

Δ After this, one of the 7 baskets, (that which is in the east) cam to Michael. and he sayd.

Mi. Seal this. For this was and is for ever

Δ Then he stode agayn on his legs like brasen pillers, and sayd

Mi. Oh how mighty is the name of God, Which rayneth in the heavens O God of the faithfull, for thow raynest for ever.

Δ he opened the basket, and there cam a great fyre out of it.

Δ -
Note of
7 Baskets

.1.

Mi. Divide the 7 partes of the circle next unto that which
thow hast done, every one, into 7.
Note: (for the tyme will be long:) Seven, rest in 7: and the
7, live by 7: The 7, govern the 7. And by 7, all Govern=
ment is. Blessed be he: yea blessed be the Lord: prayed
be our god: His Name be magnified: All honor and Glory be
unto him now and for ever. *Amen.*

Δ Then he toke oute of the fire in the basket, a white fowle like a pigeon
That fowle had a **Z** upon the first of 7 feathers which were on his brest .
that first feather was on the left side

Mi. Note. there is a mysterie in the Seven. which are the 7 governing the 7
which 7 govern the earth. Halleluyah.

Mi. Write the letters; Δ Now, a small **I** in the second fether. Then he covered
those first two letters, with the other feathers
The third an **I**, like the other: then he covered that allso.
the fowrth an **R** he covereth that
the fifth a great roman **H**. he covereth it.
the sixth feather hath a little **i**. then he hid that feather,
the last feather had a small **a**.

Mi - Prayse god.

Δ Then he put the fowle into the basket - and set it down by him. Then
he hong it up in the ayre by him.

Δ Then he lift up his sworde over us, and bad us pray. Δ We prayed.

2.

Δ Then he stretched out his hand and there cam an other basket to him.
and he pluckt out a White byrd, much bigger than the other: as big as a
swan: with .7. feathers on the brest

Mi - *Dixit, et factum est*

Mi. Note: Δ - the first feather hath a little **a**, on it: and it went
away: the next a **Z** great as the first
Then a **C** great

Then a little **a**

Then an other little **a**

Then a feather with a little **c**

Then one with a little **b** Δ Then he covered them all.

Mi - Thow hast truth.

Δ Then he put up the fowle into the basket; and hung it up by the
other in the ayre

Δ Than the third Basket cam to him, and he toke out a byrd all green
as grass. Like to a peacock in form and bignes

Mi. *Et vivis tu cum illo: et
regnum tuum cum illis est*

Δ There started out of this birds brest, 7 fethers, like gold, and fyrie

Mi. Pray.

3.

Mi. Note. Δ on the first feather a small **p**

Then a small **a**

a little **u**

Then a small **p**

Then a small **n**

then a small **h**

Then a small **r**. Then he put the fowle up into the Basket, &c.

Δ Then there cam an other basket to his hand.

Mi. *Dedit illi potestatem in cælis.*
Potestas illius magna est.

Orate. Δ – We prayed.

4. Δ Then he pluckt out a fowle, greater than any of the other, like a griphen (as commonly they are figured) all red fyry, with skales like brass. Then on the seven skales, appered letters.

Mi. Note. Δ – first a little **h**
a little **d**
a little **m**
Then a little **h**
Then a little **i**
Then a little **a**
Then a little **i**

Δ then he put up the fowle, & hung the basket in the Ayre.

Δ Then there cam an other basket to him.

[Δ Note: all this while the firmament was not to be seen.]

Mi. *Magnus est DEUS in Angelis suis.*
et magna est Ilorum potestas in Cælis.

Orate. Δ We prayed.

5. Δ Then he pluckt out a bird like an Egle: all his body like Gold and he had a little circle of feathers on his brest: and on it, betwen fowre parallell lines, twelve equall squares: and on the top, on the myddle, one, like the other twelve, thus.

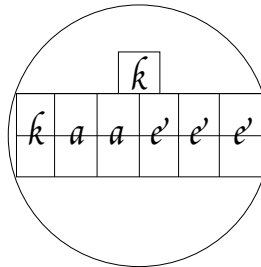

Δ Then he put up the Egle, *etc.*

Δ Then cam an other Basket.

Mi. *Nuncius tuus est magnus in cælis.*

Orate.

Δ He, and the Basket that wer opened, shut, and set aside, seamed all to be gon. and the Baskets remaying still hanging on the border of the Canapie. Then he cam agayn, and went awaye agayne. Then cam URIEL and held the Basket: and his leggs seemed to be such great tall pillers of Brass. as Michael did stand on before.

Δ. Michal was the sixth name *vide post*

UR. This is a Mysterie. He is here, and not here which was here before.

6.

Δ He opened the Basket and pluckt out like a phenix [Δ or pelican] of the bignes of a swan, all fyrie sparkling. His byll is bent into his brest and it bled. In his brest was a quadrangle made with his own feathers, thus. He put it up, and hung it by the other Baskets.

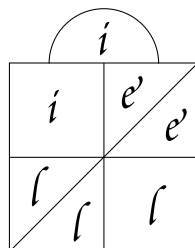

Then cam the last basket. Uriel stode still and sayde:
 UR. *Dedit angelis potestatem in lumine cæli.*
Orate. Δ We prayed.

7 Δ Then cam Michael, and toke the Basket of Uriel and becam standing
 on the great brasen legs, as before.
 Δ He toke out of the basket a strange fowle with many wings:
 This fowle had in his forhed a Tablet of this fashion

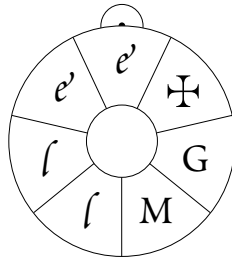

Mi. *Et Coniunxit illos DEUS in Unum.*

Δ All the Baskets flew up: and so the Canapie vanished away: and the Heaven appeared.

Δ Now he cam and sat down in his chayre.

Uriel. Δ Michael sayd to Uriel: it is thy part, to expownd these Mysteries: Go to, in the name, of our God.

Δ Uriel cam and stode before him and sayde: What will you: Ô our fellows, and servants to GOD? What will you?

My contynuall
and auncient
prayer

Δ Perfect Knowledge, and understanding, such as is necessary for us.

UR. Looke uppon, and see if thow canst not understand it: We will depart for a little space: and come to the agayne.

Δ So they went: and left all the stone on fyre, so that neyther the Chayr or Table could be seen in it.

Δ After a quarter of an howre, Michael and Uriel cam both agayne.

Mi. Loke into the 7 angles next unto the uppermost Circumference.

Δ Uriel cam and stode before Michael.

UR. Those 7 letters, are the 7 Seats of the One and everlasting

Δ Note these manifold and great Mysteries and mark these 7 diverse crosses with these 7 letters.

GOD. His 7 secret Angels proceding from every letter and Cross so formed: referred in substance to the FATHER: in forme, to the SONNE: and Inwardly to the HOLI GHOSTE. Loke uppon it: it is one of the Names, which thow hast before. every letter conteyning an Angel of brightnes: comprehending the 7 inward powres of God; known to none, but him self: a sufficient BOND to urge all Creatures to life or Death, or any thing els conteyned in this world. Yt banisheth the wicked, expelleth evyll spirits: qualifieth the Waters, strengthe neth the Just, exalteth the righteous, and destroyeth the wicked. He is ONE in SEVEN; He is twice THREE.

Note this Bond.

Δ - He is twice three and one

He is Seven in the Whole. He is Almighty. His Name is everlasting. His Truth can not fayle. His Glory is incomprehensible. Blessed be his name. Blessed be thow, (our GOD) for ever.

UR. | Thow must refer thy numbers therein conteyned, to the Upper Circle. For, From thence, all things in the inward partes, shall be comprehended.

Looke if thou understand it

Δ I find it to be **GALETHOG**;

UR. it is so. Δ – I thank God and you, I understand now (aliso) the numbers annexed.



Ur. As this darkness is lightened, by the spirit of God, herein; So will I lighten, yea so will the Lord lighten your Imperfections, and glorifie your myndes to the sight of innumerable most holy and unspeakable Mysteries.

Ur. To the next part. Δ Michael sat still, with his sword in his hand.

7 Angels.

Ur. The parte wherein thou hast labored, conteyneth 7 Angels. Dost thou understand it? Δ – Not yet: Ur. Oh how far is mans Judgment from the Celestiall powres? Oh how far are these secrets hidden from the wycked? Glory be unto him; which seeth for ever. Δ – *Amen, Amen, Amen.*

Ur. Note. We can not tary long.

Thow must set down these letters onely, by 7, in a spare paper: thus.

UR. Rede _____ Begyn at the first, and rede downward. Δ I rede thus, **Zaphkiel,**

Zadkiel, Cumael *z l l R H i a* **Raphael, Haniel, Mi=**

chaël, Gabriel, *a z C a a c b* Ur. Thow hast red right

Δ – praised be God. *p a u p n h r* Ur. Thus dost thou see, how

mercifully God dea= *h d m h i a i* leth with his servants.

k k a a e' e' e'
i i e' e' l l l
e' e' l l M G †

Every letter here, conteyneth or comprehendeth the number of 72 Vertues. Whose names thou shalt know: skarse yet revealed to the world.

Uriel and Michael jointly together prononced this blessing on us.

UR. } We bless you: your { sowles
Mi. } { Harts
 { Bodyes
 { and all your doings.

Δ Michael with his sword, and flame of fyre florished over our heds. Yet I will thus much show you, for your cumfort beside. What seest thou? Δ – he spake to the skryer. and he saw an innumerable multitude of Angels in the chamber or study about us, very bewtifull with wyngs of fyre. Then he sayd, Lo, thus you shall be shaddowed from the wicked. Kepe these Tables secret. He is secret that liveth for ever.



Innumerable multitudes of Angels]

Man is frayle. Fare well.



He must

(Δ – of this sentence cam no frute nor farder confirmation. Therefore consider.)

Δ I have hitherto forgotten to ax wher Uriel his name may appere.

Δ 48 letters are here: and one is noted by a Cross: which maketh the 49th. Of this cross and Angels vide anno 1584, July 25.

72:

Vertues multiplied by 48: give 3456.

The L.
Mowntegles
bokes

go for the bokes, els they will perish. Δ – He ment that my partner Ed. Talbot, shold go to fatch the bokes from Lancaster (or therby) which were the Lord. Mowntegles bokes, which Mr. Mort yet hath: wherof mention is made before.

ended *hora. 5. a meridie*

Tuesday the 20 *Martii*

1582



Wensday. 21. *Martii*, *circa 2. a meridie*

Note this
Trumpeter Δ

After appearance was had, there cam in one before Michael (who sat in his seat) and Uriel leaned on the table (as he, usually did). This seemed to be a trumpeter: he was all in white, and his garments bespotted with blud. he had nothing on his hed. his heare very long hanging behynde him on his sholders. The Trumpet seamed to be gold. The sownd therof was very playne.

We were
commanded
not to ax
of the appa
rayle of
Michael. }

Δ I axed of my skryer, in what manner Uriel now shewed, (and Michael likewise.) Then Michael said, I warned the for axing of my apparell or manner.

Et hæc est Gloria illius, quæ non commovebitur ab impiis.

Mi. *Quid vultis? Δ – Juxta voluntatem Dei, Sapientiam nobis necessariam ꝑc.*

Mi. *Sapientia mundi, nihil est, peribit autem in æternum.*

Veniat æternitas DOMINI, ab universis mundi partibus.

Phanaël

*Venite, venite, sic vult DEUS ADONAY
fac officium Phanaël.*

Δ This Phanaël was the Trumpeter, (above mentioned) who thereupon blew his Trumpet, Lustily, turning him self rownd abowt, to all the world. Then, from 7 partes of the world, (being equally divided abowt the Horizon,) cam 7 Cumpanyes of Pillers all of fyrye cullour glittring. And every Cumpany of Pillers high and great and as though they were Pillers of fyre.

The Heaven, the Sonne, and, Mone and Sterrs seemed to tremble.

Mi – *Multiplex est Deus noster.*

Mi. Mark this Mystery Seven comprehendeth the Secrets

of Heven and erth: Seven knitteth mans sowle and
body together. (3, in sowle, and 4 in body)

In 7, thow shalt finde the Unitie

In 7, thow shalt finde the Trinitie

In 7, thow shalt find the Sonne, and the proportion of the Holy Ghoste. O God, O God, O God, Thy Name (O God,)

be prayed ever, from thy 7 Thrones, from thy 7 Trumpets and from thy 7 Angells. Δ – *Amen, Amen, Amen.*

7 < Thrones
Trumpets
Angells

Mi. In 7, God wrowght all things.



Note: In 7, and by 7 must you work all things

O Seven tymes Seven, Veritie, Vertue and Majestie
I Minister by thy licence This expownd, by thy
Vertue (Δ – Michael spake that, pointing to Uriel.)

Δ Michael and Uriel both kneeled down, and the Pillers of fyrie
and brasen cullour, cam nere, rownd abowt them uniformly.

Mi – *Sic est DEUS noster*

Δ One of the pillers leaned toward the skryer, and had like
a pommel or mace hed, on the top of it. And Michael with
great reverence toke out of the top of it a thing like an **S**

Δ Then leaned down **6** Pillers more: and Michael, cryed lowd

Unus est DEUS noster, Deus Deus noster

Δ Then orderly he opened all the pillers heds: and then the **7** joyned
all together, distinctly to be discerned

Mi. Note. Δ – There appeared, a great **S**

A

A

I

Δ Then the sides closed up, and hid those letters first shewed.

After that appered two letters more. **E**

M

Δ He made cursy, and semed to go fromward, and vanished away.

MUOTEPLOY est E 8

Δ The Pillers all joyned together at the tops, making (as it were) one
Mace or Pommell, and so flew up to heven wards.

NOTE Δ There seamed two pillers more to come down from heven
(like the other in forme) and toke place there, where the
other **7**, stode, which went away.

Note the intrusion of Error by the Wicked powres of Sathan

Δ Michael with his sword, Cut them asunder: and cryed out,

Away you workers of Iniquitie

Periit Malus cum malis.

Δ The pillers fell down, and the grownd swallowed them up.

Tanta est tua audacia Sathan.

Sed DEUS noster Vivit.

Δ The Pillers which before ascended, cam down joyntly: and oute
of them a Voyce saying ^ΔNON SUM

Δ Then the **7** pillers next his right hand, bowed to Michael, And
oute of them, a Voyce sayd *SUM*

Δ Then one of the Pillers stode higher than his fellows, and Michael
opened all the tops of them; and sayd

Orate. Δ – We prayed.

Mi. Write the Name down in the Tables.

Δ Then he toke of, **3** of the heds of the Pillers, and sett them downe
and there appered, **B T Z**, great letters in hollow places like
square Cumfit boxes.

Mi. *Ista sunt secreta secretorum*

Δ
Non Sum
I understand
the refusall of
those two
intruded
pillers

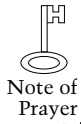

Invoke Nomen eius, aut nihil agere possumus.

The key of Prayer openeth all things. Δ – We prayed.

Then the other 4 pillers, bowingly shewed 4 letters thus, **K A S E**, and the number **30** with a prik under
Then the Pillers joyned theyr heds together very close, and flew up into the firmament with Thunder.

Sic Domine, Sic Sic.

Mi – Place these in the Table Δ – I wrote and he sayd, Thow hast done right. *Laudate nomen Domini, qui vivit in æternum.*

Δ – A voyce cam out of the next cumpany of the 7 pillers (joyning them selves to gither) saying *Ipse.*

Mi – *Et Misericordia tua Domine magna est.*

Δ – Michael kneled whan he sayd this

Δ – Michael shewed out of 4 of theyr heds, of the pillers, (and with all sayd) NO, NOT the Angels of heven, (but I,) are privie of these

things: Δ – So there appeared, 4 letters, **H E I D**

Δ – Then the other 3 pillers were opened and had **E N E** on theyr tops

Dominus collocatur in numero suo.

Δ – The 7 pillers mownted up into the ayre, and it thundred at their going

Δ – Then the fowrth Cumpany of pillers bowed to Michael: out of them cam a voyce. *Vivo sicut LEO in medio illorum*

Mi. *Et tua potestas magna est Ubique*

Δ – Then Michael pluckt of, five of the tops.

There appered **D** then they joyned all to gither: then appere? **E I M O**

Mi. *Hoc est sine præce*

Δ – The other two opened, and there appeared **30 A**

Δ – Then they closed up, and went away, with a great thunder

Δ – Then cam 7 other pillers to Michael, and a voyce oute of them
Saying, *Serpens sum, et devoravi serpentem.*

Mi. *Et bonis et malis serpens es Domine*

Δ – Then they closed all up; and Michael sayd, *Orate.* Δ – We prayed

Δ – Then Michaël toke of, the heds of 4: then appeared first an **I** then **M E G**

Then he opened the other 3. and **C B E** appeared.

Mi. *Numerus illius, est nulli cognitus.*

Δ – They joyned theyr heds all together, and ascended up to heven ward: and great lightening after them.

Δ – Then cam an other Septenarie of Pillers: and oute of them a Voyce, saying
Ignis sum penetrabilis

Mi – *Et sit nobiscum, Ô Deus.* Pray. Δ – We prayed.

Δ – Then he opened 4 of theyr heds and appered in them **I L A O.**

Δ – They closed together agayne.

Δ – Then one other was opened, and **I** appered.

Δ – Then **21** appered, and did shut up agayn.

Δ – Then he smote fyre out of the last pyller, and it thundred and there seemed to come out of it innumerable Angels like little children

Note these Innumerable Angels.

There is
V omitted
by our
neglect

with wings, and there appere: **N**, and suddenly did shut up.

Sic, sic, sic Deus noster.

Δ – Then they joynd all together, and flew up.

Mi. Note down in the table. Δ – I noted them down.

Δ – Then cam the last 7 pillers, and out of them this voyce,
Finis.

Gaudium et Lux nostra Deus.

Δ – Then they closed all in one.

Mi – *Orate* Δ – We prayed.

Δ – Then **6** of the heds opened and appered **I H R L A A.**

 Δ – Then the seventh opened: Then seamed trees to leap up,
and hills, and the seas and waters to be trubbled, and thrown up

Δ – A voyce cam out of the Pillers: *Consummatum est.*

Δ – There appeared in that Piller **21**
8

Δ – They joynd together and flew up to heven ward.

Mi – **VNVS VNVS VNVS**

Omnis caro timet vocem eius

Pray. Δ – We prayed.

Δ – Note: my skryer was very faynt, and his hed in manner gyddy, and his eyes,
dasyling, by reason of the sights seen so bright, and fyrie, *etc.*
Michael bad of him be of good cumfort, and sayd he shold do well.

 Mi – Cease for a quarter of an howre.

Δ – After we had stayed for a quarter of an howre, we comming to the
stone agayne, fownd him come all ready to the stone: and Uriel
with him. Who, allso, had byn by, all the while, during the
Mysterie of the .7. pillers.

Mic – Set two stoles in the myddst of the flowre.

 on the one, set the stone: and at the other let him knele.
I will shut the eares of them in the howse, that none shall heare
us. I will shew great Mysteries.

Michael than, with a lowd voyce sayd,

Adeste Filiaë Bonitatis:

Ecce DEVS vester adest:

Venite.

*Filiaë Bonita=
tis, or Filiolæ
lucis: vide
pagina sequente.*

Δ – There cam in 7 yong women appalled all in Grene, having theyr heds rownd abowt
attyred all with greene silk, with a Wreath behinde hanging down to the grownd.
Michael stroke his sword over them, no fyre appearing. Then they kneeled: And
after, rose agayn.

Mi – *Scribe quæ vides.*

Δ – One of them stept out, with a little blue tablet in the forhed of her: and
in it written, **El.**

Δ – She stode a side, and an other cam in, after the same sort, with a great **M**, and a
little **e**, thus, **Me.**

The Third, cam as the other, and had **Ese**

The fowrth _____ **Iana**

The fifth _____ **Akele**

The sixth _____ **Azdobn**

The seventh stepped furth with — **Stimcul**

Δ – They all together, sayd, Nos possumus in Cælis multa.
 Δ – Then they went they way, suddenly disapering.
 Mi – Note this in your next place but one. Δ – I did so.

*Filiolæ
Lucis*

Mi – Go to the next place. Stay.

Mi – *Adeste, Filiolæ Lucis.*

Michael:
one of them
that are
cownted to
stand before
the face of
God.

Δ – They all, cam in agayn, and answered, *Adsumus Ô tu qui ante
faciem DEI stas.*

Mi – *Hiis nostris benefacite.*

Δ – They answered, all, *Factum erit.*

Mi – *Valete.*



*Filii
Lucis*

Mi – *Et dixit Dominus, venite Filii Lucis.*

Venite In Tabernaculo meo.

Venite (inquam): Nam Nomen meum exaltatum est.

Δ – Then cam in 7 yong men, all with bright cowntenance, white apparaled,
with white silk uppon theyr heds, pendant behinde as the women had.
 One of them had a rownd purifyed pece or ball of Gold in his hand.
 One other had a ball of silver in his hand.

Metalls

The third a ball of Coper.

The fowrth a ball of Tynne in his hand.

The fifth had a ball of yern.

The sixth had a rownd thing of Quicksylver, tossing it betwene his two hands.

The last had a ball of Lead.

They wer all apparayled of one sort.

Perhaps
here
wanteth
non

Mi – *Quamvis ^ in uno generantur tempore, tamen unum sunt.*

Δ – he that had the gold ball, had a rownd tablet of gold on his brest.

and on it written a great

I _____

Filii Lucis

Then he with the sylver ball, cam furth, with a golden tablet on his brest

likewise, and on it written

Ih _____

He with the Copper ball, had in his tablet

Ilr _____

He with the tyn ball, had in his tablet

Dmal _____

He with the yern ball, had in his tablet

Heeo, and so went asyde

He with the Mercury ball, had written

Beigia _____

The yong man with the leaden ball, had

Stimcul _____

Mi – *Facite pro illis, cum tempus erit.*

Δ – All answered, *Volumus.*

Mi – *Magna est Gloria Dei inter vos. Erit semper. Halleluyah.*

Valete.

Δ – They made cursy, and went they way, mownting up to heven.

Mi – *Dixit Deus, Memor esto nominis mei:*

Vos autem immemores estis.

I speak to you. Δ – Hereupon, we prayed.



Filiae filiarum

Mi – *Venite, Venite, Venite.*

Filiae Filiarum Lucis Venite.

forte quae

Qui habebitis filias venite nunc et semper.

Note these three
descents.



Dixit Deus, Creavi Angelos meos, qui destruent Filias Terræ.

Theyr attyre

*Adsumus, Δ – Sayd 7 little wenches which cam in.
They were covered with white silk robes, and with
white about their hed, and pendant down behinde,
very long.*

Mi – *Vbi fuistis vos?* Δ – *They answered: In terris, cum sanctis
et in cælis, cum glorificatis.*

Δ – These spake not so playn, as the former did; but as though they had an
Impediment in theyr tung



*Filiae
Filiarum*

Δ – They had, every one, somewhat in theyr hands, but my skryer could not judge
what things they were. Mi. *Non adhuc cognoscetur Mysterion hoc.*

Δ – Each had fowre square Tablets on theyr bosoms, as yf they were of white Ivory.

Δ – The first shewed on her Tablet a great **S**

The second _____ **Ab**

Ath The third _____ **Ath**

The fourth _____ **Ized**

The fifth _____ **Ekiei**

Madimi The sixth _____ **Madimi**

The seventh _____ **Esemeli**

Mi – *Quid istis facietis?*

Erimus cum illis, in omnibus operibus illorum. Δ – They answered.

Mi – *Valete.* Δ – They answered, *Valeas et tu Magnus O in Cælis.*

Δ – And so they went away.



Filii filiorum

Mi – *Orate.* Δ – We prayed.

Mi – *Et misit filios filiorum, edocentes Israel.*

Mi – *Dixit Dominus, Venite ad vocem meam.*

Theyr Attyre

*Adsumus, Δ – Sayd 7 little childern which cam in,
like boyes covered all with purple, with hanging sleeves
like preists or scholers gown sleeves: theyr heds attyred all
(after the former manner) with purple sylk.*

Mi – *Quid factum est inter filios hominum?*

Male vivunt (sayd they) nec habemus locum cum illis

tanta est illorum Iniustitia. Veh mundo, scandalis:

Veh scandalizantibus, veh illis quibus Nos non sumus.

Δ – These had tablets (on theyr brests) three cornerd, and seemed to be very grene
and in them, letters. The first had two letters in one: thus, of **E, L:**

E

The first _____ **EL** — Δ He sayd, *Nec nomine meo timet Mundus.*

The second _____ **An** _____ *Nullus videbit faciem meam.*

The third _____ **Ave** — *Non est virgo super terram cui dicam.* [Δ And
pointed to his tablet, wherein that
word, Ave, was written.]

Rocle

The fourth _____ **Liba** _____ *Tanta est infirmitas sanctitudinis Diei.
Beneficientes decesserunt ab illo.*

The fifth _____ **Rocle** _____ *Opera manuum illorum sunt vana.
Nemo autem videbit me.*

The sixth shewed his

Hagonel. *Vide de
hoc Hagonel, lib. 4.*

Tablet and said, *Ecce – Hagonel – Qui adhuc Sancti sunt, cum illis vivo.*

The seventh had on his tablet — **Ilemese** — *Hii imitaverunt doctrinam meam.*
In me Omnis sita est Doctrina.

Δ — I thought my skryer had missherd, this word *Imitaverunt*,
 for *Imitati sunt*. And Michael smyled and seemed to lawgh,
 and sayd, *Non curat numerum Lupus*. And farder
 he sayd, *Ne minimam detrahet a virtute, virtutem*.

Mi — *Estote cum illis: Estote (inquam cum istis) Estote*
(inquam) mecum. Valete.

Δ — So they went, making reverence, and went up to heven.
 Mi — *Dictum est hoc tempore.*

Mi — Note this in thy Tables.
 Dost thow understand it? Loke if thow canst.

Urielis
 officium

Δ — He sayd to Uriel, it is thy part, to interpretate these things.

Ur. *Omnis Intelligentia est a Domino.*

Mi — *Et eius Nomen est Halleluyah.*

Compose a table, divided into 7 parts, square.

Note this
 Table is
 made
 perfect in
 the next
 side
 following.

S	A	A	I ²¹ / ₈	M ^E	E ^M	E ⁸ / ₈
B	T	Z	K	A	S	E ³⁰ / ₈
H	E	I	D	E	N	E
D	E	I	M	O	³⁰ / ₈	A
I ²⁶ / ₈	M	E	G	C	B	E
I	A ^L	L ^A	O	I ²¹ / ₈	V ²¹ / ₈	N
I	H	R	L	A	A	²¹ / ₈

7. Names
 of God

Ur. Those 7 names, which procede from the left hand to the right, are the
Names of God, not known to the Angels: neyther can be
 spoken or red of man. Prove if thou canst reade them.

*Beatus est qui secrete
 Nomina sua conservat.*

Note these
 two orders
 of Angels:
 and Note
 Uriel doth
 have him self
 one of the standers
 before the face of God

Ur. These Names, bring furth 7 Angels: The 7 Angels, and Go=
vernors in the hevens next unto us*, which stand allwayes
before the face of God.

*Sanctus Sanctus Sanctus
 est ille DEVS noster.*

Ur. Every letter of the Angels names, bringeth furth 7 dowghters.

NOTE
 well this
 Rule of
 Arte.

{ Every dowghter bringeth furth her dowghter, which is
 { 7. Every dowghter her dowghter bringeth furth, a
 { sonne. Every sonne in him self, is 7. Every sonne

hath his sonne, and his sonne is 7.

Let us praye the God of Seven, which was and is
and shall live for ever.

Vox Domini in Fortitudine

Vox Domini in Decore

Vox Domini revelat Secreta.

In templo eius, Laudemus Nomen eius El

Halleluyah

Filiae

See if thou canst now understand this table.

The Dowghters procede from the angle on the right hand, cleaving
the myddle: where theyr generation ceaseth.

Filii

The sonnes from the left hand to the right to the middle:

so proceding where theyr number endeth in one Centre.

The Residue thou mayst (by this Note) understande.

Note this
manner of
center
accoun=
ted.

Δ —

Then Michael, he stroke over us ward, with his sword, and the flame
of fire yssued oute.

Note of Numbers
with priks
signifying letters.

Loke to the Corner of the right hand, being the uppermost: where thou
shalt finde **8**. Refer thyne eye to the upper number, and the
letter above it. But the Number must be fownd under neth,
bycause his prick so noteth.

Than procede to the names of the dowghters in the Table: and thou
shalt see that it is the first name of them: This shall teache
the.

l the first
daughter

Δ —

Loking now into my first and greatest Circle for **8**, I finde it with
l over it. I take this to be the first Dowghter.

Ur.

You must in this square Table set **E** by the **8** and now
write them composedly in one letter, thus **E**

E

Nomen Domini vivit in æternum.

Ur.

Give over, for half an howre, and thou shalt be fully
instructed.

Δ —

I did so, and after half an howre comming to the stone,
I was willed to make a new square table of 7: and
to write and note, as it followeth.

S	A	A	I ²¹ ₈	E	M	E ⁸	– <i>Vivit in cælis</i>
B	T	Z	K	A	S	E ³⁰	– <i>Deus noster</i>
H	E	I	D	E	N	E	– <i>Dux noster</i>
D	E	I	M	O	30	A	– <i>Hic est</i>
I ²⁶	M	E	G	C	B	E	– <i>Lux in æternum</i>
I	L	A	O	I ²¹ ₈	V	N	– <i>Finis est</i>
I	H	R	L	A	A	²¹ ₈	– <i>Vera est hæc tabula</i>

*Vera est hæc Tabula, partim nobis cognita, et partim omnibus,
incognita. Vide iam.*

Note these
other pur=
poses

The **30** by **E**, in the second place, in the upper right corner, serveth not
in the consideration of the first Dowghters, but for an other purpose.

The **26** by **I**, serveth for an other purpose: but not for this Dowghters Dowghter.

The **21**, is **e**, and **8** with the prick under it is **l**: which together maketh **El**, or thus compounded as if it were one letter, **EL**

The Names in the great Seale must follow the Orthographie of this Table. *Virtus Vobiscum est.*

Orate. Δ – We prayed.

Δ – Then there appeared **S A A I 21 M EL** . Here is an **E** comprehended in **L**.
Ur. Read now the Table.

*Angeli
Lucis*

Angeli lucis Dei nostri

Et posuit angelos illius in medio illorum

Ur. In the table are the names of 7 Angels. The first is Zabathiel, beginning from the left uppermost corner: taking the corner letter first, and then that on the right hand above: and than that under the first, and than the third from the first, in the upper row: and then cornerwise down toward the left hand: and then to the fowrth letter from the first in the upper row: where there is **I** with $\frac{21}{8}$, which maketh **el**. So have you **Zabathiel**.

1.

2. Ur. Go forward. Δ – So, I finde next **Zedekieil**.

The true sownd Ur. this **I** in the last syllable augmenteth the true sownd of it.

3. Δ – Then next I finde **Madimiel**. — Ur. it is so.

4. Δ – Then ————— **Semeliel**. — Ur. it is true.

5. Δ – Then ————— **Nogahel**. — Ur. it is so.

6. Δ – Then ————— **Corabiel**. — Ur. it is so.

7. Δ – Then ————— **Levanael**. — Ur. it is so.

Δ This name
Corabiel you
may see in *Ele=*
mentis Magicis Petri
de Abano in the
Considerations Diei)

Ur. Write these names in the Great Seal, next under the 7 names which thow wrotest last: *videlicet*, under **EL**, **An**, **Ave**, *∅C*. distinctly in great letters.

Ur. Make the **E** and **L** of **Zabathiel**, in one letter compounded, thus **ZABATHIEL** . In this, so fashion your **E** and **L**. And this name must be distributed in his letters into 7 sides of that innermost Heptagonum. For the other, I will teache you to dispose them. You must make for **IEL** (in this name onely) **I** with the $\frac{21}{8}$ annexed. So have you just 7 places.

Ur. The next five names thow shalt dispose in the five exterior angles of the Pentacle: every angle conteyning one whole name.

Ur. Set the first letters of these 5 names, (in Capitall letters) within the five acute internall angles of the Pentacle: and the rest of eche name following circularly from his Capitall letter, but in the 5 exterior obtuse angles of the Pentacle.

Ur. Set **Z**, of **Zedekieil** within the angle which standeth up toward the begynning of the greatest Circle. And so procede toward thy right hand.

Ur. In the middle now of thy Pentacle, make a cross  like a crucifix and write the last of those 7 names **Levanael** thus,

VA
LE  NA
∅

Uriel. *Vidit DEVS, opus suum esse bonum
et cessavit a Labore suo.
Factum est.*

Δ – Michael stode up and sayd,
The æternall Blessing of God the FATHER,
The mercifull Goodnes of CHRIST, his SONNE
The unspeakable Dignitie of GOD the Holy GHOSTE
bless you, preserve you, and multiply your
doings in his Honor and Glory.

Uriel. *AMEN.*

Ur. | These Angels are the angells of the 7 Circles of Heven,
governing the Lightes of the .7. Circles.

Note these
two order
of Angels

| Blessed be GOD in us, and by us,
| Which stand contynually before
| the presence of GOD, for ever.

DIXI.

Δ – Whan may we be so bold, as to require your help agayn?

Mic – Whan so ever you will, we are ready.

Farewell.

Δ – *Sit Nomen Domini benedictum, ex hoc nunc,
et usque in sæcula sæculorum.*

Amen.



Anno Domini } At
1582 } Mortlake by
Martii 21. } Richemond



Mysteriorum, liber
Tertius Δ

Anno 1582:

Aprilis 28:

Liber 3⁹
Liber 4⁹

Anno 1582 Aprilis 28 a meridie hora 4.

E.T: Onely Michael appeared; Δ: And to diverse my complaynts, and requests sayde,

Mi: The lord shall consider thee in this world, and in the world to come.

E.T: All the chayre seemed on fyre.

Mi: This is one Action, in one person: I speak of you two.

Union
of us

Δ: You meane us two to be joynd so, and in mynde united, as yf we wer one man?

Mi: Thou understandest.

Take heade of punishment for your last slaknes.

Δ: Yf you mean any slaknes on my behalf, Truely it was and is for lak of habilitie to buy and prepare things, appointed of you. Procure I pray you habilitie, and so shall I make spede.

E.T: A great hill of gold with serpents lying on it appeared: he smyteth it with his sword, and it falleth into a mighty great water, hedlong.

Mi: Dost thow understand? Δ: No verylie.

worldly
hability

E.T: He razed the hill away, as though there had byn none; and sayd,

Mi: Lo, so it is of this worldly habilitie.

Δ: I pray you how must the Lamine be hanged?

The
Lamin
not simplr
spoken: for
no such lamyn
was to be
made

Mi: As concerning the Lamine, it must be hanged unseen, in some skarf.

The Ring when it is made, I will lessen it according to my pleasure.

I meane by two Cubites, your usuall yarde.

Haste, for thow hast many things to do.

Glory be to God, Peace unto his Creatures. Mercy to the wicked,

Forgivenes to the Faithfull: He liveth, Ô he rayngneth, O

Pele
Ese

thow art mighty, PELE: thy name be blessed. Δ: Amen.

Venito Ese, Δ: He cryed so with a lowd voyce.

E.T: he is now covered, in a myghty covering of fyre, of a great beawty.

There standeth a thing before him. I cannot tell what it is.

Laudate Dominum in cælis.

Orate. Δ: we prayed.

E.T: His face remayneth covered with the fyre, but his body uncovered.

Mi: *Adesdum Ese.*

Iana

Adesdum Iana.

Vobis dedit demonstracionem in Tabulis vris.

E.T: There appeare of the figure, (before, imperfect) two little women: One of them held up a Table which lightened terribly: so that all the stone was covered with a myst.

A voyce cam out of the myst, and sayd,

Creatio

Ex hiis creata sunt, et hæc sunt nomina illorum.

E.T: The myst cleareth, and one of the women held up a Table, being thus written uppon.

Numerus Primus.

Δ: The Table semed square, and full of letters and numbers, and Crosses, in diverse places, diversly fashioned.

Δ: Remember, Ese and Iana; ar the thirdth and fowrth of the *Septem Filiæ Bonitatis, supra lib^o. 2. °* They are thus in order these: EL, Me, Ese, Iana, Akele, Azdobn, Stimcul.

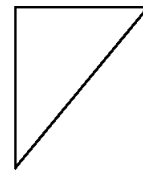

A finger cam out of the mist, and wyped oute, the first shew, with the Cross, letters, and numbers.

The second was in like wise.

The Third was a b with the taylor upward thus: *g*

The 52 with the three great **BBB** seme to be covered with Gold.

The two Crossed ones he did not wipe out with his finger.

The next he blotted oute.

He blotted not oute the three $\frac{b}{f}$ with the 8 and 3.

The two barrs must go clere $\frac{b}{b}$ and not towch the $\frac{b b b}{b b b}$ the bars.

The , the square, wherin it standeth, is all gold: and that he let stand.

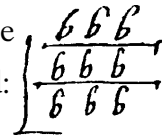

Fire cam oute and burnt

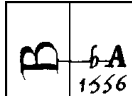

The  is all of a bright cullour, like the brightnes of the Sonne, and that was not put out.

The places are very black, but where the letters, and numbers do stand.

E.T. hard a voyce saying, *Finis Tenebrarum: Halleluyah.*

E.T: There commeth a hand and putteth the little woman into the clowde.

Mi: Prayse God: Be inwardly mery.

The Darkness is comprehended.

God bless you: God bless you: God blesse you.

You must leave of for an howre and a half: for you have .6. other

Tables to write to night.

Prayse God: be joyfull.



After supper we resorted to our scholemaster.

E.T: I here a voyce but see nothing: he sayeth,

Initium bonum in nomine ejus

et est. Halleluyah.

E.T: Three quarters of the stone (on the right side) are dark, the other quarter is clere.

Filiae filiarum
Ese
vide lib. 2º

Mi: *Venite filiae filiarum ESE.*

Δ somewhat wanteth

The nethermost

E.T: There come six yong maydens, all in white apparell, alike:

Now they all be gonne into the dark parte of the stone, except one.

There cam a flame of fyre out of the dark, and in the flame written

Vnus on this manner:

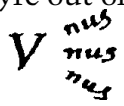

She that standeth without, putteth her hand into the dark: and pulleth out a ball of light: and threw it oute: and it waxed bigger and bigger and it Thundred.

Lux

E.T: A voyce sayd, *Dies primus.*

An other voyce : *Ubi est Tabula?*

an answer : *Est, Est, Est.*

She wyndeth and turneth her self abowt, begynning at her hed, and so was Transformed into a Table, rownde.

E.T: Three faces do shew and shote oute, and ever returned into one hed agayne: and with it cam a mervaylous swete savour.

The Table cullored

The Table was of three cullours: white, redd, and a mixture of white

Numerus Primus

2 6 + 6 3	G b b	g	B 22	2.4.6 b b b 2 4 6	L b	B rog	Ⓟ
8 b b 2	ff 8	G b	gg b	152 b	152 b	52 BBB	B + B
Ⓟ q q	b ° ° °	B 7 9	b b b b b b b b b	11 B 5	b b b b	b b b	b 8 b 3
b b b b b b	b b b b 15 b b b b	b M 166	7 △ b b	Ⓟ b 5	G M +	B b A 1556	
b 1	D 2 3 b 123	b	T b	4 BB 9	BBB 6 b	b b 72 F	b

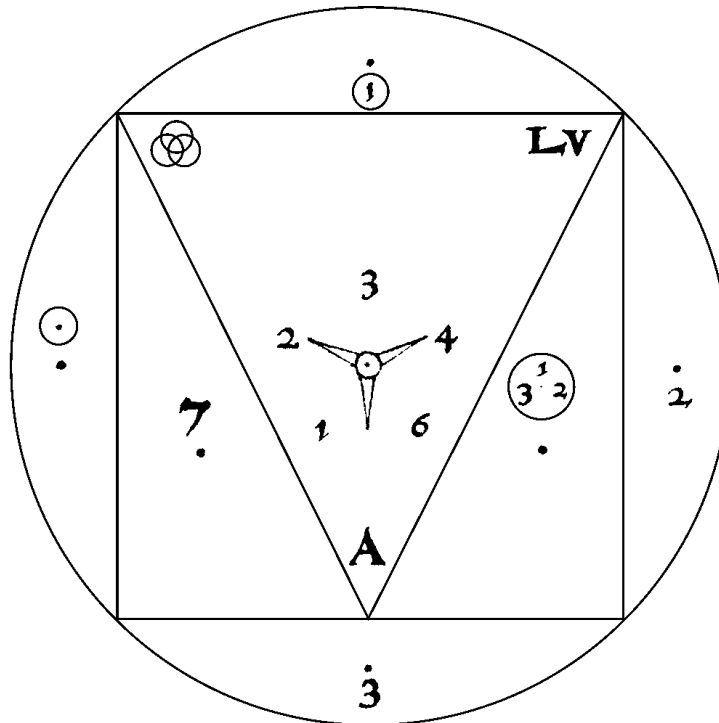

Δ Of these seven tables, characters, or scotcheons consider the words spoken in the fifth boke A° 1583, Aprill 2d How they are proper to every King and prince in their order.

They are Instruments of Conciliation

/Volumine 5°/

where my Character is fashiond

G 23 B T	m · 30 q B · 9 · d · 4 ·	q · q · q Q B o · g og
J B 30 G 33 · A	T H B A 9 O	E B get h go
S C b ↗	d2 id d b 2A	L b 30 pp
V b H 9 22	q · q · q Q b og a	L b 25 d

2 bb 2	b b ▽	537 bbb	b B G n	T · 13 bbb	b j
v · 2 B	o 4 BB	B 14 n	bb · b P · 3 ·	b GO	bb C · v 3
8 e b	Q · 0 b 7 b	∞ 5	q q b 3	q · 9 B	L ^b · 8
go 30 B	9 · 3 b b	q q · b · b	d T b T ^b A	7 · 2 b · B	BB · Λ · 8 3

and red, changeably. A strong sowing cam withall, as of clattring of harness or fall of waters; or such like.

There cam a sterre shoting oute of the dark, and settled itself in the myddle of the Table: And the fyre which cam oute with the woman, did cumpas the Table about.

A voyce sayd, *O honor, Laus et gloria, Tibi qui es, et eris*

The Table sheweth wunderfull fayre and glorious.

Onely seven priks appeare on the Table.

The three angles of the triangle open, and in the lower point appeared a great **A**.

And in the right upper corner **LV**. (E.T: The Table trembled.)

And in the other Corner appeared thre circles of equall bignes, equally, or alike intersecting eche other  by theyr centers.

A voyce: *Unus est, Trinus est; in omni Angulo est.*

Omnia comprehendit: Fuit, est, et vobis erit.

Finis et Origo. (E.T: ô, ô; with a dullfull sownd, he pronouncd.)

E.T: The woman sayeth, *Fui: sum quod non sum.* ^{Δ forte fui}

A voyce: *Lux non erat et nunc est.*

E.T: The woman being turned, from the shape of the Table, into womans shape agayn, went into the dark.

Then one part of the darknes diminished. In the dark was a mervaylous turmoyling, tossing, and stur, a long tyme during.

A voyce: For a tyme Nature can not abyde these sightes.

E.T: It is become Quiet, but dark still.

Prayer A voyce: Pray and that vehemently, For these things are not revealed without great prayer. 

E.T: After a long tyme there cam a woman: and flung up a ball like a glass: and a voyce was hard saying, *Fiat*.

The ball went into the darknes, and browght with it a great White Globe hollow transparent.

Then she had a Table about her neck, square of 12 places.

The woman seamed to daunce and swyng the Table:

Then cam a hand oute of the dark: and stroke her and she stode still, and becam fayrer: She sayd, *Ecce signum Incomprehensibilitatis*;

Water E.T: The woman is transformed into a water, and flyeth up into the Globe of Light. 

E.T: A voyce: *Est, Est, Est.*

Erth E.T: One commeth, (a woman) owt of the Dark, very demurely, and soberly walking, carrying in her hand a little rownd ball: and threw it into the dark: and it becam a great thing of Earth. She taketh it in her hand agayne, and casteth it up into the rownd Globe and sayd, *Fiat*.

E.T: She turned her back toward E.T. and there appeared a Table divided in 24 parts. yt seemeth to be very square.

A voyce: *Scribe. Veritas est.*

Man
Woman

E.T: A sword cam out of the Dark: and clave the woman a sunder, and the one half becam a man, and the other a woman, and they went and sat uppon the Ball of cley or erth. 

Now seemeth the Dark part to quake.

A voyce ——— *Venito vasedg.*

E.T: There cometh a woman oute of the Dark: she sayd,

Vita hiis ex mea manu.

E.T: She sheweth a Table square full of holes, and many things creeping out of it. This Square is within a rownd.

A voyce ——— *O Lux Deus noster.*

Hamuthz Gethog.

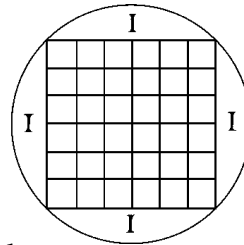

E.T: Then stept out an other woman having a sword in her hand. She toke a thing oute of the dark (a bright thing) and Cut it in twayn and the one parte she cut into two unequal partes, and the other half she cutteth into a thowsand (or innumerable) partes. Then she toke all the partes up into her skyrt. She hath a Table, and it hangeth on her shulders. She stept before the other woman, whose hed standeth in the dark.

Note this stepping before.

This woman her Table is fowre square. She is very bewtifull.

She sayd, *Lumina sunt hæc Intelligentiæ tuæ.*

She sayd, *Fere nulli Credendus est hic numerus.*

The sterrs, sonne and Mone created

This woman taketh the little peces, and casteth them up, and they become little sparks of light: and of the things she cast, There were two great rownd things. And they were also cast up to the white Transpa= rent Globe. And she went away into the Dark: which was, now, very much lessened.



Then the other woman (who was forestept) thrust oute her hed who had the rownd conteyning the Square, with the 36 places.

She crymbleth clay, and it turneth to byrds. She seameth to be like a witch. Into the bosse of her Table, she put her hand and that bosse, was in the Dark and oute of the bosse, she seemed to fatch that Clay. She sayd,

Ad usum tuum Multiplicati sunt.

E.T: She went into the Dark.



<i>f</i> D 2 <i>f</i>	B f 30	B B 8 2	B 0 2.2	B·O p 30	L 0 B·q q·29	B 8 2	$\frac{9}{6}$ B
o p B 9 8	H; C B	tt 2. 8 G	ff 9 F	b 3 e	bbb 9 Q	b u e	BB i 2 T
BB b 8	M 2 b b	M b s	M b b b 20	M b·8 9 F	d B 17	A b 3	B B H
M b 99 L	b 6 T 4 b	b 2 T b	bb T 9 16	6 B 2 4	T B 38	N B 9	b b 4 b

Note this cross with the two bees, the 4 and the 6, is one of the Notes annexed to the second Table of the 4 of Enoch's Tables: And the T of Enoch's Tables semeth to answer with the T first in the scale of Aemeth, and the cross also.

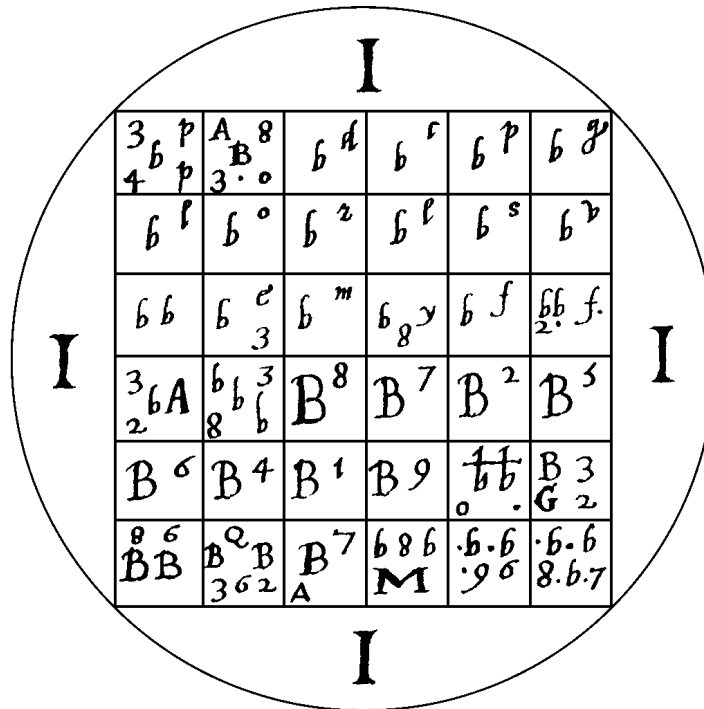

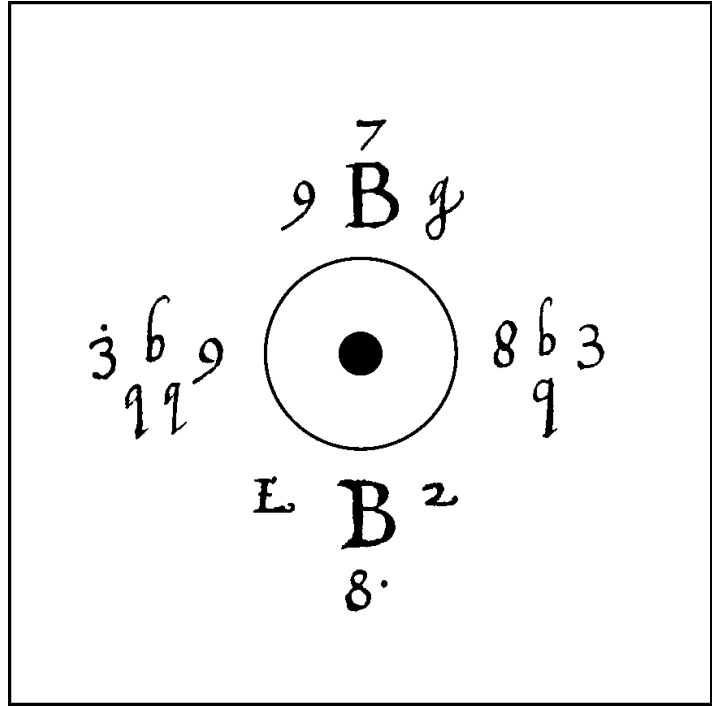

E.T: A Voyce is hard saying,
Omnia gaudent fine.

...| hearbs,
&c.

E.T: There commeth oute a woman; out of the Dark. She plucketh at the dark, and casteth it on the grownd, and it turneth to herbes, and plants becomming like a garden, and they grow up very fast. She sayd,
Opus est.

...| Centre }
...| Darknes }

E.T: She hath a fowre square Table before her.
Then cam one, all in white, and taketh the Darknes, and wrappeth it up and casteth it into the myddle of the Erthen Globe, on which appeared Trees and plants.

E.T: Then appered Michael, his Chayre, and Table agayne manifestly: which all this while, were not seen.

Mi: *Obumbrabit vestigia vestra veritatia Luce.*

The Actor, The Actor, The Actor:

One Disposer; he, which is one in all; and All in all:
bless you from the wickednes of Deceyte: Create you new vessels: To whome I commyt you.

E.T: he holdeth his sword over us, in manner, out of the stone.

Mi: Fare Well. Serve God. Be patient.

Hate vayne glorie. Live justly. Amen.

Δ: What spede shall I make for the yard square Table, the wax, the seale, and the Character? Mi: As thow ar motioned, so do.

Δ: *Gloria, Patri et F. et S.S. S.e.i.p.e.n.e.s.e.r.s.s. amen.*

Δ: Note, All the Tables before were by E.T, letter for letter noted out of the stone standing before him all the while: and the 7 Tables following wer written by me as he repeted them orderly out of the stone.

Aprilis 29: Sunday: Nocte hora 8 1/4

E.T : Two appeare, Michael and Uriel.

Mi: *Et posuit illos in ministerium ejus.*

Quid desideratis?

Δ: *Sapientiam et scientiam nobis necessariam, et in Dei servitio potentem ad eius gloriam.*

Mi: *Sapere, a Deo: Scire a Creatura et ex creaturis est.*

Δ I am not sure
if it wer Mi.
or Ur, that
called for them.

Ur: *Venite filiae.*

E.T: Seven women appeare bewtiful and fayre.

Mi: This work is of wisdom (Δ: Sayd Michael, and stode up.)

E.T, sayd to me (Δ), He putteth oute his sword and willeth me to sweare, to that, that he willeth me: and to follow his cownsayle.

Mi: Wilt thou. Δ: Then with much ado, E.T. sayd as followeth,

E.T. his
promise

E.T: I promise, In the name of God the Father, God the sonne and God the holy ghost, to performe that you shall will me, so far as it shall lye in my powre.

E.T: Now they two seeme to confer together.

Mi: Now you towche world, and the doings uppon earth.

practise.
The lower
world

Now we shew unto you the lower world: The Governors that work and rule under God: By whome you may have

powre to work such things, as shalbe to god his glorie, profit of your Cuntrie, and the knowledge of his Creatures.

To E.T. he spake,

What I do wish thee to do, thow shalt here know, before thow go. We procede to one GOD, one knowledge, one Operation.

Filiae

Venite filiae.

49 good Angels Governors

Behold these Tables: Herein lye theyr names that work under God uppon earth: not of the wicked, but of the Angels of Light. The whole Government, doth consist in the hands of 49 (in God his Powre, Strength, Mercy, and Justice) whose names are here evident, excellent, and glorious.

The first knowledge

Mark these Tables: Mark them. Record them to your [... This is the first knowledge. Here shall you have Wisdome. *Halleluyah.*

Mighty and Omnipotent art thow, O God, God, God, amongst thy Creatures: Thow fillest all things with thy excellent foresight. Thy Glorie be amongst us for ever. Δ: Amen.

E.T: All the 7 (which here appeare) joyne theyr Tables in One, which, before they held apart. And they be of this Forme all to_gither. The myddel most is a great Square and on eche side of it, One, as big as it, joyning close to it. And over it joyned two, which both together wer æquall to it: and under it, wer such other two, as may appear in this little pattern. Being thus joyned, a bright circle did cumpas and enclose them all, thus: but nothing was in the Circle.

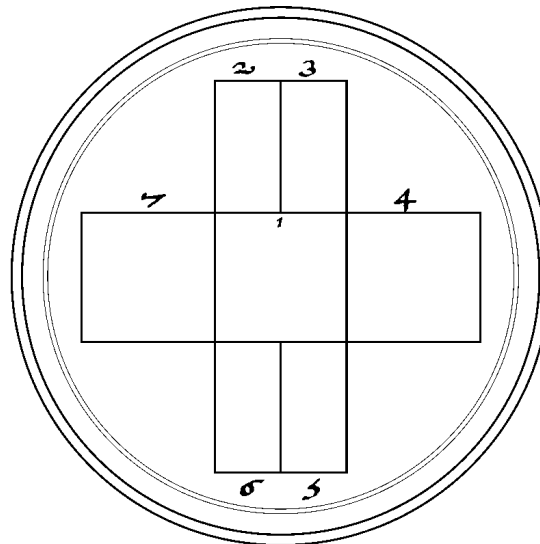

2

7 A	21 O	1 A	26 E	48 A	24 A	13 R				
34 I	8 O	29 M	2 O	33 A	6 M	25 E				
49 A	4 E	35 A	40 M	18 L	28 M	23 L				
39 V	47 L	3 A	5 L	15 A	36 N	30 R				
20 E	19 R	45 A	37 R	32 I	17 A	41 A				
10 A	38 O	16 V	27 A	12 R	43 R	22 Y				
9 E	44 A	11 E	42 L	31 A	14 N	46 V				

7

14 E	49 E	7 F	25 A	13 I	47 F	16 O	1 B	2 B	3 B	4 B
46 A	36 N	44 L	42 N	18 M	45 O	6 L	8 B	9 B	10 B	11 B
12 O	41 O	26 I	43 A	29 L	39 B	33 S	15 B	16 B	17 B	18 B
48 T	31 O	2 O	32 B	9 S	38 A	8 L	22 B	23 B	24 B	25 B
28 S	15 L	17 A	10 O	3 O	30 S	20 E	29 B	30 B	31 B	32 B
40 L	34 N	37 S	19 P	4 E	5 O	22 R	36 B	37 B	38 B	39 B
24 R	1 N	35 O	23 N	11 E	21 N	17 A	43 B	44 B	45 B	46 B

36 E	47 E	14 L	27 F	49 D	13 L	16 N				
12 L	32 A	26 G	24 O	41 R	31 L	19 O				
22 O	29 O	2 G	7 D	25 R	1 O	5 P				
6 A	15 E	34 O	4 M	33 E	30 E	20 L				
37 E	9 E	18 O	10 L	21 O	28 E	3 D				
17 M	39 A	35 G	38 L	8 E	11 L	23 O				
44 O	43 Z	48 R	40 O	45 B	42 A	46 A				

6

3

6 A	7 S	29 A	15 B	23 I	8 B	17 Z
36 A	39 S	12 A	30 O	1 L	10 S	21 N
5 V	31 S	25 L	45 B	26 N	32 N	3 P
18 I	19 A	48 R	4 S	27 R	34 N	24 L
38 R	44 G	37 A	20 R	16 T	2 R	22 N
49 M	43 V	35 R	47 I	9 F	33 R	42 I
13 I	46 S	11 R	41 R	40 I	28 I	14 A

4

1	4 B	5 B	6 B	7 B	6 M	41 T	39 C	19 G	49 N	45 L	14 G
1	11 B	12 B	13 B	14 B	31 P	25 M	2 N	18 N	44 E	8 O	30 R
1	18 B	19 B	20 B	21 B	7 L	15 A	38 M	32 O	43 M	29 S	28 L
1	25 B	26 B	27 B	28 B	35 D	37 L	3 N	13 S	42 I	12 N	33 I
1	32 B	33 B	34 B	35 B	1 I	17 P	16 M	46 D	5 M	40 N	21 E
1	39 B	40 B	41 B	42 B	27 N	23 S	4 G	36 P	26 P	47 N	20 M
1	46 B	47 B	48 B	49 B	9 A	10 M	24 C	22 E	34 O	11 N	48 F

8 G	41 I	16 O	48 O	43 A	7 A	49 O
3 D	19 I	44 N	13 F	47 G	38 I	3 I
7 E	15 A	2 O	27 A	42 G	10 E	18 T
31 A	12 G	25 A	20 A	40 P	15 L	29 P
6 G	23 D	22 P	1 G	30 G	5 A	46 V
37 G	9 F	4 E	24 E	34 F	33 G	21 F
36 S	45 I	26 A	14 O	39 N	11 O	18 G

5

The Circle abowt was bright
and Nothing in it./

- ET: One stept furth, and sayde,
 1: { Wilt thou have witt, and wisdome:
 Here, it is. (Δ: Pointing to the middle table.)
 2: { An other sayd, The Exaltation and Government of Princes, is in my
 hand. (Δ: Pointing to that on the left hand of the two uppermost.)
 3: { In Cownsayle and Nobilitie I prevayle. (Δ: Pointing to the other of the
 two uppermost: which is on the right hand.)
 4: The Gayne and Trade of Merchandise is in my hand: Lo, here it is.
 Δ: he pointed to the great table on the right side of the myddle Table,
 that I meane which is opposite to our right hand while we behold
 those 7 Tables.
 Δ I mar= 5: The Quality of the Earth, and waters, is my knowledge,
 vayne that the earth and waters are both ascribed to one. and I know them: and here, it is. (Δ: pointing to that on
 the right hand: of the two lowermost.)
 6: The motion of the Ayre, and those that move in it, are all
 known to me. Lo here they are. (Δ: pointing to the other Table
 below, on the left hand.)
 7: I signifie wisdome: In fire is my Government. I was in the be-
 gynning, and shalbe to the ende. (Δ: pointing to the great table
 on the left hand of the Middle Table.)
 Mi: Mark these mysteries: For, this knowne, the State of
 the whole earth is known, and all that is thereon.
 Mighty is God, yea mighty is he, who hath Composed for ever.
 Give diligent eye. be wise, mery, and pleasant in the
 Lorde; in whose Name, NOTE,
 Begynne the Middle Table *∅c*. Δ: I wrote oute of the
 stone the whole 7 Tables (as you see them here with theyr numbers
 and letters) while E.T. did vew them in the stone, and orderly express them.
 Δ: As concerning 39 V . 47 L *∅c* in the second Table, where are 7 places
 and there but 6 numbers and letters, and yet every place semeth to
 have a letter, in the judgment of E.T. his sight. Which is the
 Number and letter wanting, and where must it be placed?
 Mi: *Non potestis hoc videre sine ratione.*
 Δ: The Next day, as I was loking on the Tables being finished, and joyned
 all to gither in One Compownd Figure, E.T. cam to me, and
 stode by me, and his ey was on the forsayd place which I was forced to
 leave empty, in the 7th and last. And behold he saw hovering and
 hopping in the ayre, ∴ over the sayd place, and the next before it.
 And that, which I had placed the sixth, was to be put in the seventh
 place, and that which was wanting, was to be set in the sixth place
 being 30 N.
 E.T: Every of the 7 Tables, as they wer written out of the stone
 do seme afterward to burn all in fyre: and to stand in fyre.
 E.T: After all the Tables wer written, eche toke hir Table aparte agayn
 and stode in theyr order.
 E.T: Note moreover. The First, had Bokes in hir hand.
 Kings ————— The second, a crown in hir hand.
 Nobilitie ————— The Third, Robes.
 Merchants Δ — *Aqua* — The fowrth, *animal quadrupes vicium omnim colorum.*
Terra — The fifth, Herbes.
Aer — The sixth, a fanne.
Ignis — The seventh, a Flame of fyre in hir hand.

Δ
 This I inter=
 sert now;
 though it wer
 not at the
 first Noting.
 two numbers and
 two letters cuppled
 to them.

Mi: *Decedite in nomine eius, qui vos huc misit.*
 E.T: Uriel opened a boke in his own hand, and sayde,
 A boke Ur: The Fowntayne of wisdome is opened. Nature shalbe
 knowne: Earth with her secrets disclosed.
 The Elements with theyr powres judged.
 Loke, if thow canst (in the name of God) understand these
 Tables. Δ: No: Not yet.

Erthly Actions Ur: Beholde; I teache. There are .49. Angels glorious and excellent,
 appointed for the government of all earthly actions: which 49 do
 work and dispose the will of the Creator: Limited from the
 begynning in strength, powre, and glorie.

Practise These shalbe Subject unto you, in the Name, and by Invo=
 cating uppon the Name of GOD, which doth lighten, dispose and
 Cumfort you.
 By them shall you work, in the quieting of the estates, in learning
 of wisdome: pacifying of the Nobilitie, judgement in the
 rest, as well in the depth of waters, secrets of the Ayre, as in the
 bowells and entrails of the Earth.

We two to_gither Ur: Theyr Names are comprehended within these Tables. Lo, he teacheth,
 he teacheth, Lo, he instructeth, which is holy, and most highest.
Take hede, thow abuse not this Excellency, nor overshadow it with
 vanitie, But stick firmly, absolutely, and perfectly, in the love
 of god (for his honor) to_gither.
 Be mery in him: Prayse his name. Honor him in his Saints. Behold
 him in wisdome: And shew him in understanding.
 Glorie be to him; To thee ô Lord, whose name perseth through the earth.
 Glorie be to thee, for ever. Δ: *Amen, Amen, Amen.*

Ur: Lo, I will breifly teache thee; you shall know the Mysteries in him:
 and by him, which is a Mysterie in all things.
 The letters are standing uppon 7 equall numbers. The Number before
 them is signifying, teaching and instructing (from the first Table
 to the last,) which are the letters that shalbe joyned to gither:
 begynning all, with B, according to the disposition of the number
 untill the 29 general names be known. The first 29 are more
 excellent than the rest. Every Name doth consist uppon the quantitie
 of the place: Everie place with addition bringeth furth his name,
 which are 49. ———I have sayde.———

*Δ
*Vide ipanum
 Tabulam ho=
 rum 49 nomen
 Collectam, pa=
 gina sequente.*
 The first 29

Δ: I pray you to tell me the first Name. Ur: The first Name is BALIGON.
 he ment to E.T. Mi: I have to say to the, and so have I done:
 Δ: Now he spake to E.T., of the matter he sware him to, at the begynning of
 this last instruction: and he told me afterward what Michael had willed
 and moved him unto. Wherat he seamed very sore disquietted: and sayd thus to me,

E.T: He sayd that I must betake my self to the world, and forsake the
 world. That is that I shold marry. Which thing to do, I have no na=
 turall inclination: neyther with a safe Conscience may I do it, contrary
 to my vow and profession. Wherefore I think and hope, there is
 some other meaning in these theyr wordes.

E.T. must marry Mi: Thow must of force kepe it.
 Thow knowest our mynde.

Δ: *Deo opt Max. omnium honor laus et gloria
 in sæcula sæculorum. Amen.*

Ended, *hora noctis, 11 1/2 circiter.*

Tabula Collecta: **49** Angelorum Bonorum, Nomina continens

per Δ

1	BALIGON
2	BORNOGO
3	Bapnido
4	Besgeme
5	Blumapo
6	Bmangal
7	Basledf
8	BOBOGEL
9	BEFAFES
10	Basmelo
11	Bernole
12	Branglo
13	Brisfli
14	Bnagole
15	BABALEL
16	BVTMONO
17	Bazpama
18	Blintom
19	Bragiop
20	Bermale
21	Bonefon
22	BYNEPOR
23	BLISDON
24	Balceor
25	Belmara
26	Benpagi
27	Barnafa
28	Bmilges
29	BNASPOL
30	BRORGES
31	Baspalo
32	Binodab
33	Bariges
34	Binofon
35	Baldago
36	BNAPSEN
37	BRALGES
38	Bormila
39	Buscnab
40	Bminpol
41	Bartiro
42	Bliigan
43	BLVMAZA
44	BAGENOL
45	Bablibo
46	Busduna
47	Blingef
48	Barfort
49	Bamnode

Coordinatio Angelorum bonorum 49,
 per Jo: Dee, ita disposita:

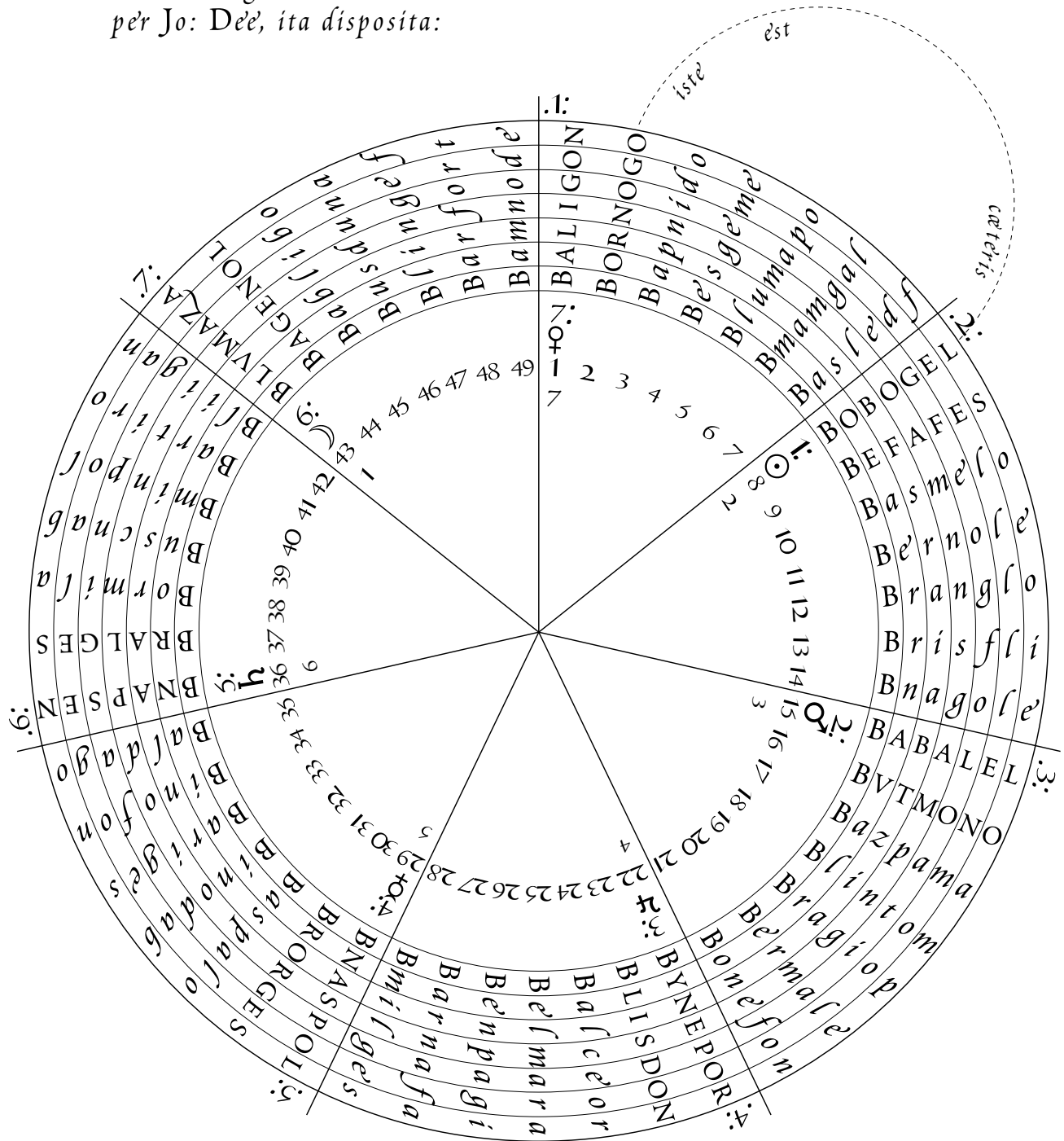

E.T. is to marry

Δ: E.T. wold not wilingly now deale with the former Creatures, utterly misliking and discrediting them, bycause they willed him to marry. Neyther wold he put of his hat in any prayer to god, for the Action with them: where=uppon I went into my Oratorie, and called unto God, for his divine help for the understanding of his laws and vertues which he hath established in and amongst his Creatures, for the benefyt of mankinde, in his service, and for his glorie &c. And commyng to the stone, E.T. saw there those two, whom hitherto, we wer instructed to be Michael and Uriel.

Uriel his manner of apparition

E.T: Michael and Uriel, both kneled holding up theyr hands: and Michael seamed to sweat water abundantly, somewhat reddish or bluddish. There cam 7 Bundells down, (like faggots) from heven ward. And Michael taketh them kneeling. And Uriel taketh a thing like a superaltare and layeth it uppon the Table: and with a thing like a senser doth make perfume at the fowre corners of the Table: the smoke ascending up: and the senser, at the last, being set on the Table it seemed to fall through the Table.

A Glorious man

URIEL semeth to be all in a white long robe tucked up: his garment full of plights and seemed now to have wyngs. (which, hitherto, from the begynning of these kinde of Actions he did not) and on his hed a bewtifull crown, with a white Cross over the Crown. Uriel taketh the .7. Bundells from Michael: and with reverence layeth them on the forsayd Superaltare.

All creatures

E.T: There commeth a man, as though he were all of perfect pure glistening gold: somtyme seeming to have One eye, and somtyme Three. From under the Table commeth a great smoke, and the place semeth to shake.

A description of the glorious man.

Uriel lieth now prostrate on his face: and Michael contynually prayed sweating. The Glorious man seemed to open the Covering of the .7. bundells (being of diverse cullored sylk,) and there appered, that these Bundells seemed to have in them, of all Creatures some, in most glorious shew.

Many cullors in all his garments are shewed in *seqientibus libris*

The glorious man seemed to stand uppon a little hill of flaming fyre. He taketh of, of one of the Bundells a thing lyke a little byrd; and it hoovereth affore him as though it had life: and than it rested uppon the thing like a superaltare.

This glorious man seemeth to be open before, and his brest somewhat spotted with blud. He hath a berd forked of brownish cullour, his heare of his hed, long, hanging down to his sholders: but his face, for beutifull glittering, can not be discerned. His heares do shake, as though the wynde carryed them.

This man blesseth the bird, making a Cross over it: and so he did three tymes. He looketh up to heven.

Now the byrd, which, before, seamed to be but as byg as a sparrow, seameth to be as great as a swanne: very beutifull: but of many cullours. Now looketh Michael up, and held up his hands to heven, and sayeth,

Sic, Sic, Sic, Deus noster.



Uriel, (sayd)-- *Multiplicabit omnia, benedictione sua.*

The former Bewtifull man taketh this fowle, setteth it on the bundell, and on the place, from whence it was taken: And, now, the place

where this byrd stode before, seemeth allso to be (proportionally) waxed big, as the byrd, (thus enlarged).

The Yoaking
or cuppling of
the two byrds.

This man taketh an other byrd, and putteth the wyng of it, behind the wyng of the first (as though he yoked them.)

This second byrd, at this his first taking, was as byg, as the first was become, (encreased, as it shewed), and it was allso a very bewtifull one.

E.T: All is suddenly dark, and nothing to be seen, neyther Chayre, nor anything els.

E.T: A voyce was hard, like Michael his voyce, saying, It was a byrd, and is a byrd, absent there is nothing but Quantitie.

Δ
E.T. sayd the
voyce to be
like Michael
his voyce.
Necessitie.

A voyce: Beleve. The world is of Necessitie: His Necessitie is governed by supernaturall wisdome,
Necessarily you fall: and of Necessitie shall rise agayne.
Follow me, love me: embrace me: behold, I, AM.

E.T: Now all the Darknes vanished, the man is gon. Uriel standeth at the Table, and Michael sitteth now in his Chayre: and sayd,

Mi: This doth GOD work for your understanding.

vayne to stryve

It is in vayne to stryve: All Government is in his hands.
What will you els, what will you els?

Δ: *Progressum et profectum in virtute et veritate ad Dei honorem et gloriam.*

Δ
forte your

Mi. This hath answered all [y]our Cavillations.

Δ What hath answered all our Cavillations?

Mi. Thow hast written.

One thing you shall see more, as a persuasion to the Infirmitie.

E.T: The two byrds, which were there, before, and gon out of sight, now are shewed agayn: but none of the bundells appere.

They seme to grow to a huge bignes, as byg as mowntaynes: incredibly byg: and they seeme to hover up in the ayre, and to fly up toward heven, and with theyr wyngs to towch the sky: And one of them with his bill seemeth to take sterrs into it: and the other bird to take them from the same byrd, and to place them agayn in the skye.
And this they did very often: and in diverse places of the heven with great celeritie.

The byrds towch
the sky and
sterrs

After this they semed to fly over Cities, and townes, and to break the clowdes in peces, as they passed: and to cause all dust to flye from all walls, and towres, as they passed, and so to make them clene.
And in the streetes, as these two Byrds flew, seemed diverse brave fellows, like bisshops, and Princis and Kings, to pass: and by the wyngs of these byrds, they were striken down. But simple seely ones, like beggers, lame and halt, childern, and old aged men, and wemen, seemed to pass so quietly, untowched and unoverthrown of these two Byrds.

And than they seemed to come to a place, where they lifted up, with the endes of theyr wyngs, fowre Carkasses of dead men (owte of the grownde) with crownes on theyr heds: wherof one seemed to be a Childe.

First these 4, seemed leane, and deade: Then they seemed quick and in good liking: And they being rayzed up: parted eche from the other, and went into 4 sundry wayes, Est, West, North and Sowth.

Great Hill

Now these two fowles having their wyngs joyned together, light uppon a great hill: and there the First fowle gryped the erth mightly and there appeared diverse Metalls, and the Fowle spurned them away, still.

Then appeared an old mans hed, heare and all, on; very much wythered. They tossed it betwene them, with theyr feete:

And they brake it: And in the hed appeared (in steede of the braynes) a stone, rownd, of the bignes of A Tennez ball of 4, cullours, white, black, red, and greene.

One of them (he that brake the skull), putteth that rownd stone to the others mowth or byll.

The other eateth or nybbleth on it, and so doth the other allso.

G

Now these two byrds, are turned into men: And eche of them have two Crownes like paper Crownes, white and bright, but seeme not to be sylver. Theyr teeth are gold, and so likewise theyr hands, feete, tung, eyes, and ears likewise All gold.

26

Crownes

On eche of these two men, ar 26 Crownes of Gold, on theyr right sholders, every of them, greater then other.

They have, by theyr sides, Sachels, like palmers bags, full of gold, and they take it oute, and seemed to sow it, as corne; going or stepping forward, like Seedmen.

E.T: Then sayd Michael, This, is the ende.

E.T: The two men be vanished away.

Mi: Learne the Mysterie hereof.

Δ: Teache us (ô ye spirituall Creatures.) than sayd Michael,

Mi: Joye and helth give unto the riche:

Open strong locks:

Be Mercifull to the wicked:

Pluck up the poore:

Read unto the Ignorant:

I have satisfied thee: Understand:

Read them over: God shall give thee some light in them. I have satisfied thee: Both, How you shalbe joyned,

By whome,

To what intent, and purpose:

What you are,

What you were,

What you shalbe, (*videlicet*) *in Deo*.

Lok up this Mysterie:

*to ET

*Forget not our Cownsayle:

Ô GOD, thow openest all things: Secret are thy Mysteries
and holy is thy name, for ever,
The vertue of his presence, here left, be
amongst you.

Δ: Amen.

Δ: What am I to do, with the wax, the Table, the ring or
the Lamine? &c.

Mi: When the things be ready, then thow shalt know, how to use them.

Δ: How shall I do for the graving of the ring; May not another
man do it, thowgh, E.T. Grave it not?

Mi: Cause them to be made up, (according to instruction) by any honest man.

Δ: What say you as concerning the Chamber, for our practise?
May my fardermost little chamber, serve, yf the bet be taken downe?

Mi: At the next Call, for the Chamber, you shall know what to do.

Δ: *Benedictus Deus in donis suis:*

et sanctus in omnibus operibus eius.

Amen. ended hor. 4 1/2

